Operation Guide

Model CX2000/CX2010/CX2020/CX2200/CX2210/CX2200/
CX2410/CX2420/CX2610/CX2620

DAQSTATION CX2000

vigilantplant.[®]



Contents

Introduction to Control Functions	4
Control Types	4
PID Control Function	4
Control Suppression Function	5
Tracking Function	6
Control Alarm Function	6
Wiring	7
Overview of Operations	8
Key Operation	8
Switching Operation Modes	8
Switching Displays during Operation Mode	8
Control Operation Display	9
List of Control Setup Items	10
Examples of Control Setup Operation	11
Control Setup Example 1: Single Loop Control	11
Control Setup Example 2: Cascade Control	15
Control Setup Example 3: Loop Control with PV Switching	20
Control Setup Example 4: ON/OFF Control	23
Setting the Display Items on the Control Group Display (Control Group Setting)	26
Displaying the Trend of PV, SP, and OUT Values	27
Switching the Operation Mode	29
Run/Stop Operation	29
Switching between Auto, Manual, and Cascade Control	29
Changing the Target Setpoint	30
Changing the Control Output	30
Switching between Remote and Local Modes	31
Switching between Automatic and Manual for the Analog Retransmission Loop	31
Changing the Analog Retransmission Output	32
Switching between Automatic and Manual for the DIO Operation Monitoring	32
Changing the DO Output for the DIO Operation Monitoring	32
Tuning Operation	33
Displaying the Tuning Display	33
Auto Tuning	33
Manual Tuning	34
Program Control Function (/PG1 and /PG2 Options)	35
Program Control Function Introduction	35
Operation Mode during Program Control	35
Operations on the Program Selection Display	35
Operations on the Program Control Display	36
Program Control Setup Operation	38
List of Parameters	44

Thank you for purchasing the CX2000. This operation guide briefly explains the main operations related to the loop control function of the CX2000. For information about all the functions excluding the communication functions, installation and wiring procedures, operating procedures, and handling precautions of the CX2000, see the electronic manual *CX2000 User's Manual (IM 04L31A01-01E)* provided on the accompanying CD-ROM. The following five manuals are provided in addition to this manual and the CX2000 User's Manual. Read them along with this manual.

Electronic Manuals Provided on the Accompanying CD-ROM

Manual Title	Manual No.	Description
CX1000/CX2000 Communication Interface User's Manual	IM 04L31A01-17E	Describes the communication functions of the CX1000/CX2000 using the Ethernet/serial interface.
DAQSTANDARD for CX User's Manual	IM 04L31A01-61E	Describes the functions and operating procedure of the software "DAQSTANDARD for CX" that comes with the package.

Paper Manuals

Manual Title	Manual No.	Description
CX2000 Installation and Connection Guide	IM 04L31A01-71E	Describes concisely the installation procedures and wiring procedures of the CX2000.
Precautions on the Use of the CX1000/CX2000	IM 04L31A01-72E	Precautions regarding the use of the CX1000/CX2000.
Control of Pollution Caused by the CX1000/CX2000	IM 04L31A01-91C	Gives a description of pollution control.

Note

- This manual provides information on the CX2000, style number "S3."
- The contents of this manual are subject to change without prior notice as a result of continuing improvements to the instrument's performance and functions.
- Every effort has been made in the preparation of this manual to ensure the accuracy of its contents. However, should you have any questions or find any errors, please contact your nearest YOKOGAWA dealer.
- Copying or reproducing all or any part of the contents of this manual without Yokogawa's permission is strictly prohibited.
- The TCP/IP software of this product and the document concerning the TCP/IP software have been developed/created by YOKOGAWA based on the BSD Networking Software, Release 1 that has been licensed from the Regents of the University of California.

Trademarks

- vigilantplant, DAQSTATION, and Daqstation are registered trademarks of Yokogawa Electric Corporation.
- Microsoft and Windows are registered trademarks or trademarks of Microsoft Corporation in the United States and/or other countries.
- Adobe and Acrobat are registered trademarks or trademarks of Adobe Systems Incorporated.
- Company and product names that appear in this manual are registered trademarks or trademarks of their respective holders.
- The company and product names used in this manual are not accompanied by the registered trademark or trademark symbols (® and TM).

Revisions

1st Edition	February, 2002	4th Edition	June, 2003
2nd Edition	April, 2002	5th Edition	May, 2007
3rd Edition	January, 2003		

Introduction to Control Functions

For further details on each function, see chapter 1, "Explanation of Functions" in the *CX2000 User's Manual (IM 04L31A01-01E)* provided on the accompanying CD-ROM.

Control Types

Control Mode

The following four control modes are available (three types of control plus analog retransmission) and can be set for each control loop. The mode can be specified for each control output terminal block (two loops per block, see page 7). However, single loop control can be specified on the control output terminal block for loops 5 and 6.

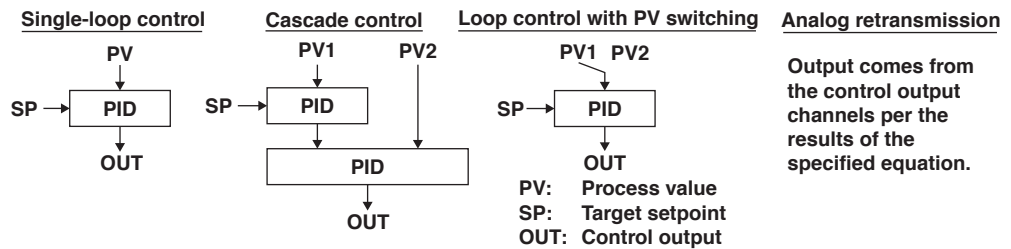

Control Operation Mode

You can specify either of the following control operation modes for each control loop. However, program control operation can be specified only on models with the program control option.

- Fixed-point control (program control OFF): Set the SP locally or use remote input
- Program control operation: Set the SP locally or use program patterns

PID Control Function

Control Computation Types and Control Output Format

You can select from time proportional PID control (voltage pulse/relay output), continuous PID control (current output), or On/Off control (relay output).

Control Direction

You can select the direction in which OUT changes according to the polarity of the deviation between the SP and the PV.

- Reverse action ($PV > SP$: OUT decreases, $PV < SP$: control output increases)
- Direct action ($PV > SP$: OUT increases, $PV < SP$: control output decreases)

PID Control Mode

You can select the change in the operation when the SP is changed.

- Follow-up: Controlled so that the output reaches the new SP quickly
- Fixed-point: Suppresses sensitive reaction of the output to change to the new SP

PID Control Method

One of the following methods is automatically selected depending on the PID control mode and the control operation mode.

- PV derivative type: Control method in which the control output is kept from changing radically when the SP is changed by a great amount
- Deviation derivative type: Control method in which fast response to follow the SP is emphasized

Control Parameter ("PID Parameter" in the Settings)

You can set up to eight groups of control parameter sets for each loop. Control parameters include SP, PID constant, control output limiter, manual reset value, control direction, and preset output.

PID Parameter Selection Method

You can select the method for switching PID parameters from the following:

- Target setpoint selection: By specifying the SP number.
- Zone PID selection: By dividing the measurement span in to multiple zones and determining in which zone the PV resides.
- Segment PID selection: Using the program pattern segment when in program control.

Tuning

There are two methods: auto tuning of PID constants using the limit cycle method, and manual tuning that allows PID parameters to be set individually during operation.

Control Suppression Function

Anti-Reset Windup (Over-Integration Prevention)

Overshoot may occur if the deviation between the SP and PV continues for an extended time and the control output reaches the output high-limit through the integration process. To prevent this from happening, the anti-reset windup function is used to pause the integration process when the manipulated output reaches the high limit of the output limiter.

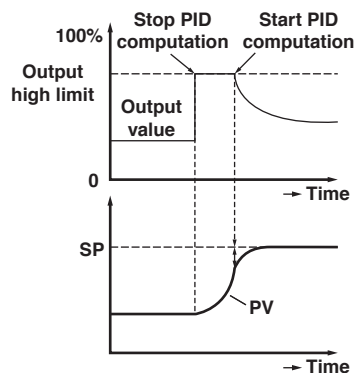

Overshoot Suppression Function (“Control Output Suppression” in the Settings)

The deviation is monitored to detect the danger of overshooting and automatically changes the SP to a slightly lower tentative value referred to as the “auxiliary target setpoint” and continues control. Then, when the process value enters a range in which overshooting is no longer a danger, the auxiliary target setpoint is gradually returned to the original SP.

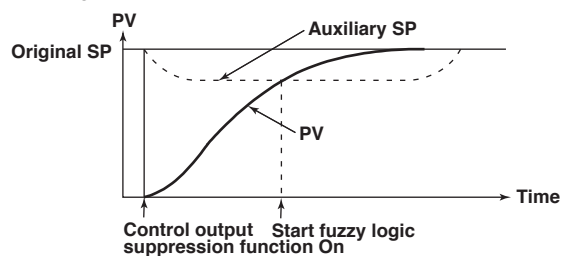

Control Output Limiter

You can set high and low limits of the control output range (“output high-limit/low-limit” in the settings) regardless of the operation mode.

Shutdown

This function is used to close the control value fully (set the output to 0) exceeding the dead band of the control valve positioner.

Output Velocity Limiter

This function is used to prevent radical changes in the control output to protect the control element and object of control.

Preset Output

This function sets the control output to the preset value when the operation is stopped.

SP Ramp-Down-Rate/SP Ramp-Up-Rate

This function is used to decrease or increase the setpoint at a constant rate of change (as opposed to a rapid change) when the SP is changed.

Target Setpoint Limit

This function is used to limit the range of values that the SP can change.

Tracking Function

You can set the following two tracking functions to suppress a radical change in the output.

SP tracking: When switching from remote to local operation mode, the output is tracked to the remote SP immediately before the SP switching.

PV tracking: The SP is matched to the PV at that point and then returned to the original value according to the target setpoint ramp-up rate or the target setpoint ramp-down rate.

Control Alarm Function

You can set up to four alarms for each loop. The following alarm types can be specified. PV upper-limit alarm, PV lower-limit alarm, deviation high limit alarm, deviation low limit alarm, deviation high/low limit alarm, deviation high and low limits alarm, SP high limit alarm, SP low limit alarm, output high limit alarm, and output low limit alarm.

Wiring

Input/Output terminals are arranged on the rear panel of the CX2000 as shown in the figure below. The figure shows the case when option terminals are specified on the model with 6 internal control loops and 20 measurement channels (CX2620). For the wiring procedure of the control/measurement input/output, see chapter 2, "Installation and Wiring" in the *CX2000 User's Manual (IM 04L31A01-01E)* or the *CX2000 Installation and Connection Guide (IM 04L31A01-71E)*. For a description on the connection of communication interfaces such as the serial or Ethernet interface, see the *CX2000 Communication Interface User's Manual (IM 04L31A01-17E)*.

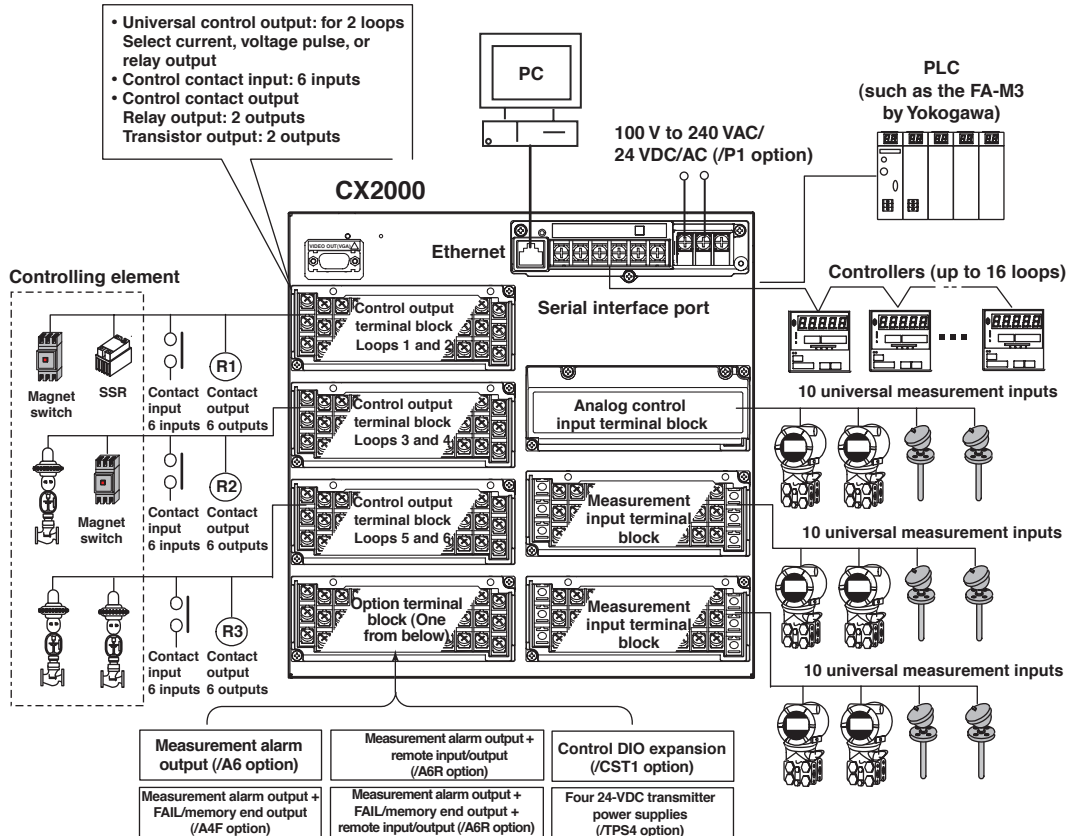

Terminal Arrangement of the Analog Input Terminal Block for 6 Loop Control (Conceptual Diagram. When PV/SP computation is OFF)

The following figure denotes the three terminals (/b, +/A, -/B) of a single column using a single cell.

PV, PV1, PV2: measurement input, (RSP): remote input (not used during program control), □: unused terminal

LOOP4	LOOP6	LOOP3	LOOP2	LOOP5	LOOP1	
2	1	1	2	1	2	[Control mode setting]
(RSP)	PV	PV	(RSP)	PV	PV	← During single-loop control
□	PV	□	(RSP)	PV	□	← During cascade control
PV2	PV1	□	PV2	PV1	PV2	← During loop control with PV switching

Terminal Arrangement of Loop 1 and 2 Control Output Terminal Block(When PV/SP computation is OFF)

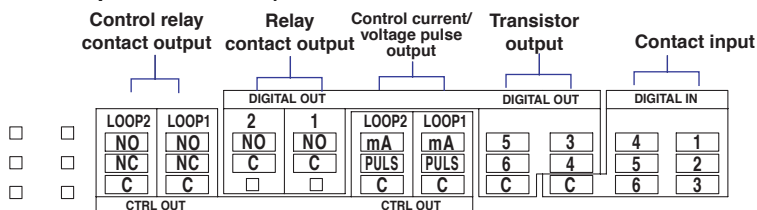

Overview of Operations

Key Operation

For details on the key operation, see chapter 3, "Names of Parts, Display Modes, and Common Operations" in the *CX2000 User's Manual (IM 04L31A01-01E)*.

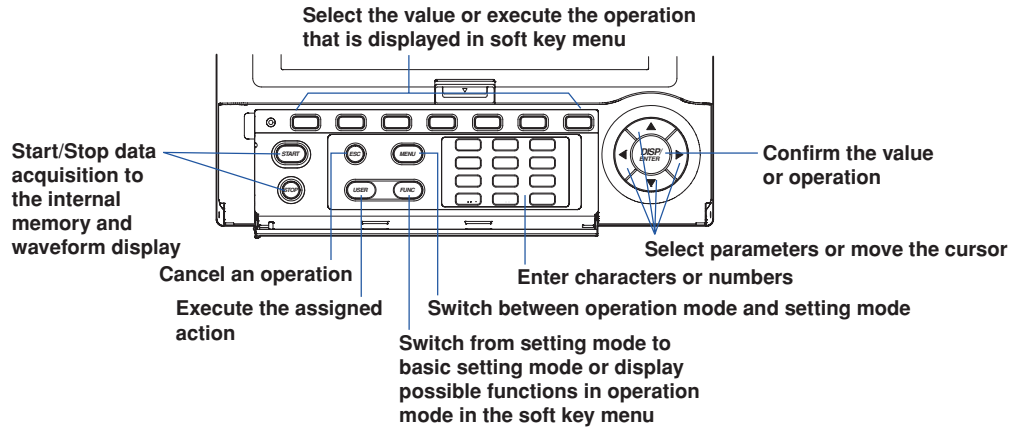

Switching Operation Modes

There are four operation modes: operation mode, control setting mode, common and measurement setting mode, and basic setting mode.

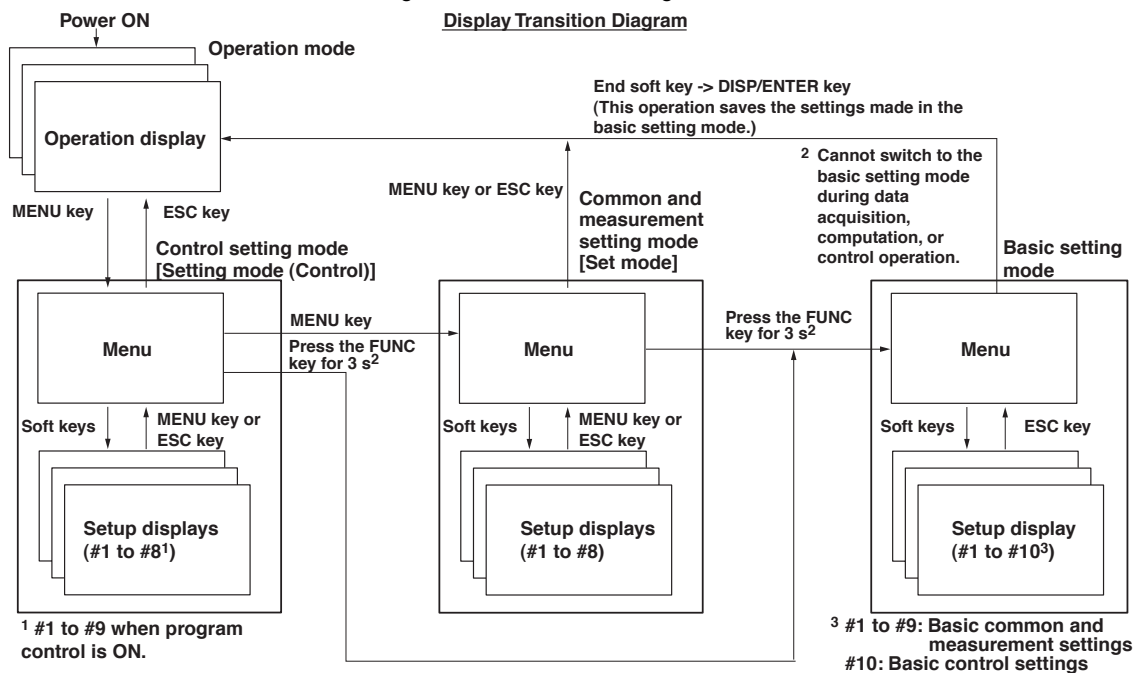

Switching Displays during Operation Mode

You can change the operation display according to your needs by carrying out the following procedures.

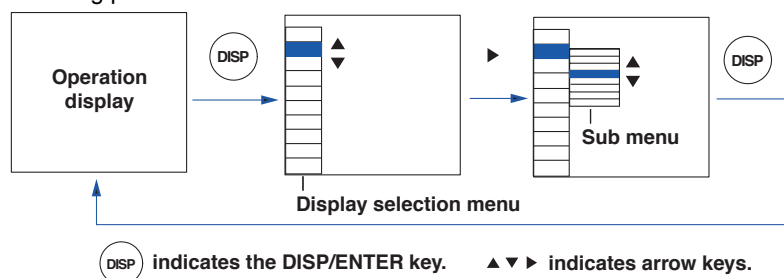

Control Operation Display

In operation mode, the following control operation displays can be selected.

- Control group display
This display is used to monitor the control status of multiple loops simultaneously including external loops. You can select from three display styles as shown in the display example in the figure below. If you include the measurement channels for the measurement function in the group, you can also monitor the measured values on the measurement channels at the same time on this display.
- Tuning display
This display is used to optimize (tune) the control parameters such as PID constants.
- Overview display
This display is used to monitor the alarm status of all control loops.
- DI/DO status display
Displays the ON/OFF status of the current contact input (DI) and contact output (DO).
- Control action summary display
Displays a log of control actions such as operation run/stop and auto/manual operation switching.
- Internal switch status display
Displays the ON/OFF status of the internal switch.

On models with the program control function option, the following additional displays are available: 1) the program operation status display, which can show the pattern and current PV accumulated on the screen during program operation and 2) the program event summary display, which shows a log of time events and PV events that occurred during program operation.

Displays common with the measurement function include: 1) the alarm summary display, which shows a log of alarm occurrence status and 2) the memory summary display, which shows the file information of the internal memory.

In addition, on the trend display of the control function, the PV, SP, OUT can be assigned to virtual channels (control channels), and the trend of control status can be displayed like the trend waveforms of measurement channels on the trend display of the measurement function.

Control group display

Display Examples



Controller style



Faceplate style



Hybrid style

Tuning display



Overview display

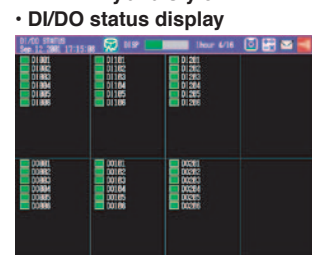

DI/DO status display

Control operation summary display • Internal switch status display

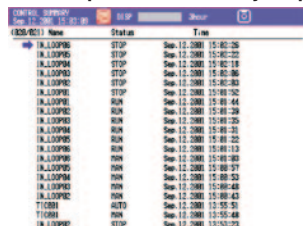

Trend display



List of Control Setup Items

Basic Control Setup Items in Basic Setting Mode

- #1 Control action, Input setting
PID number, control period, zone PID, restart mode, restart mode (program) (only on models with the program control option), initial PID, 6/4 loop select (only on models with six loops), auto tuning, control mode, method (only during loop control with PV switching), program control ON/OFF (only on models with the program control option), PID control mode, burnout, and RJC.
- #2 DI/DO/SW registration, AUX (Alarm mode)
Contact input registration, remote setting, alarm mode, SP number selection source, PV/SP math, CLOG error, and event output setting.
- #3 Output processing
Control output, cycle time, and analog-output type
- #4 Relay
FAIL ON/OFF, self diagnosis ON/OFF, and relay action/behavior (energize/deenergize, hold/nonhold)
- #5 Tuning setting
Tuning item selection
- #6 External loop setting (For details on the settings, see the *CX1000/CX2000 Communication Interface User's Manual (IM 04L31A01-17E)*.)

Setup Items in the Control Setting Mode

- #1 Control input range
Input type, mode, type, range, span, scale, unit, square root, low-cut, bias, filter, and ratio.
- #2 Control alarm
Type, standby, relay output ON/OFF, and alarm value
- #3 Operation-related parameters/Zone PID
Suppressing function, ramp-rate-time unit, SP ramp-down-rate/SP ramp-up-rate, tag, tag comment, reference point (when zone PID is selected), switching hysteresis (when zone PID is selected), and reference deviation (when zone PID is selected).
- #4 PID parameters
SP, PID constant, output limit, shutdown ON/OFF, manual reset, relay hysteresis (only during ON/OFF control), reverse/direct, and preset output.
- #5 Control group setting
Group name, kind (internal loop/external loop/measurement channel), and number.
- #6 Ten-segment linearizer I/O
Input type, mode, and biasing or approximation input/output values.
- #7 Program control (only when program control is ON)
 - #1 Program parameter setting
Pattern initial setting, wait action setting, pattern start setting, program pattern setting, event setting, hysteresis (PV event), and repeat action setting.
 - #2 Event output setting
 - #3 AUX (auto message, display position)
 - #4 AUX (event group)
- #8 Detailed setting (When program control is OFF, Detail setting is #7)
 - #1 Control function
SP tracking, PV tracking, SP limiter, output velocity limiter, and anti-reset windup auto/manual.
 - #2 Hysteresis (Alarm)
 - #3 DIO monitor and operation setting
 - #4 DI/DO label setting
- #9 Control math setting (When program control is OFF, Control math setting is #8)
 - #1 PV/SP math, Retransmission
 - #2 Logic math (#1 when both PV/SP computation and analog retransmission are inactive.)
 - #3 Constant (#2 when both PV/SP computation and analog retransmission are inactive.)
Constant used in computations for control

Examples of Control Setup Operation

Control Setup Example 1: Single Loop Control

Object of Control and Description

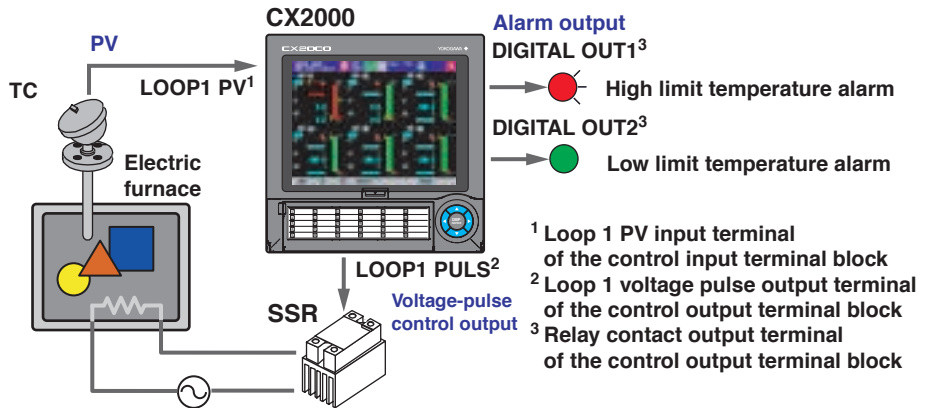

- Loop number: 1
- PID constant: P = 5%, I = 240 s, D = 60 s
- Control direction: Reverse
- Input type: TC K type
- Measurement span: 0 to 1200°C
- Output type: Voltage pulse (cycle time: 3 s)
- Temperature setpoint: 700°C
- Alarm output: PV high-limit alarm (high limit: 800°C), PV low-limit alarm (low limit: 600°C)

Basic Control Settings

- From the operation display, open the basic control setting menu according to the following procedure.
 Press the **MENU key** (to switch to Set mode), then hold down the **FUNC key** for 3 s (to switch to basic setting mode). Press the **Next 1/2 soft key**, then the **#10 soft key** (to select Control).

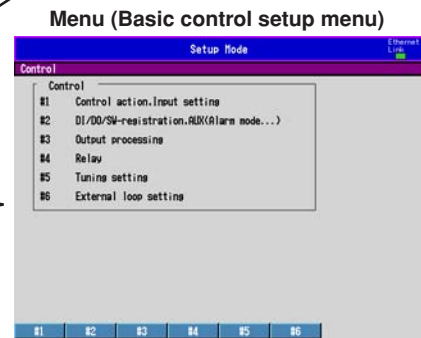
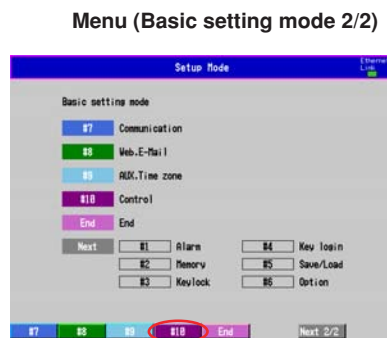
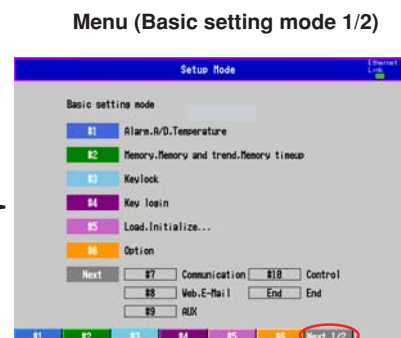
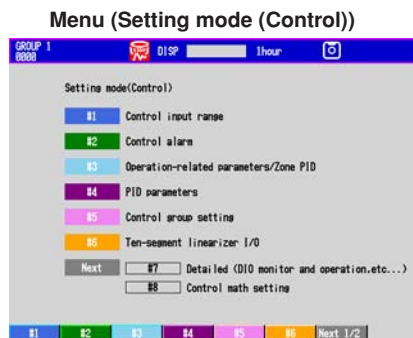

Examples of Control Setup Operation

2. Press the **#1 soft key** (Control action, Input setting).
3. Press the **arrow keys** to move the cursor (blue) to the setup item box, press the **soft key** of each value according to the following figure, and then press the **DISP/ENTER key**.

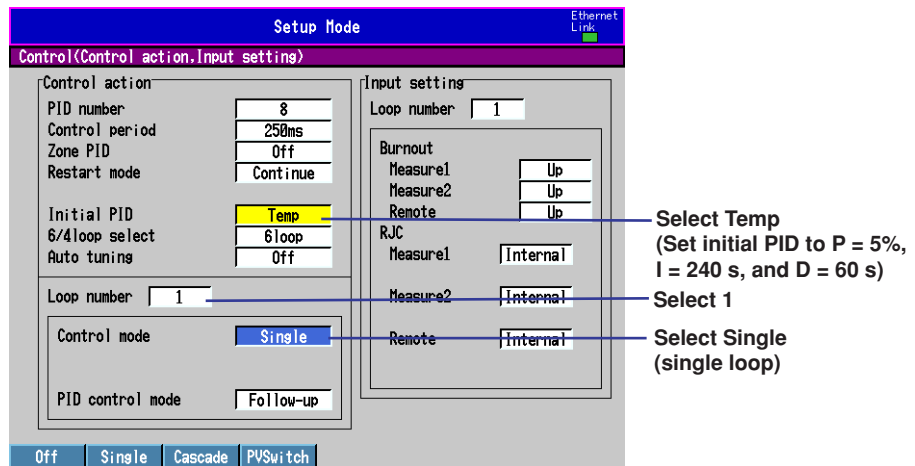

4. Press the **ESC key** to return to the basic control setting menu.
5. Press the **#3 soft key** (Output processing).
6. Press the **arrow keys** to move the cursor (blue) to the setup item box, press the **soft key** of each value according to the following figure, and then press the **DISP/ENTER key**.

To set Cycle time, press the **Input soft key** to open a numeric entry pop-up window as shown in the figure below. Enter the value using the **Character/Number key** and the **Space soft key** and then press the **DISP/ENTER key**.

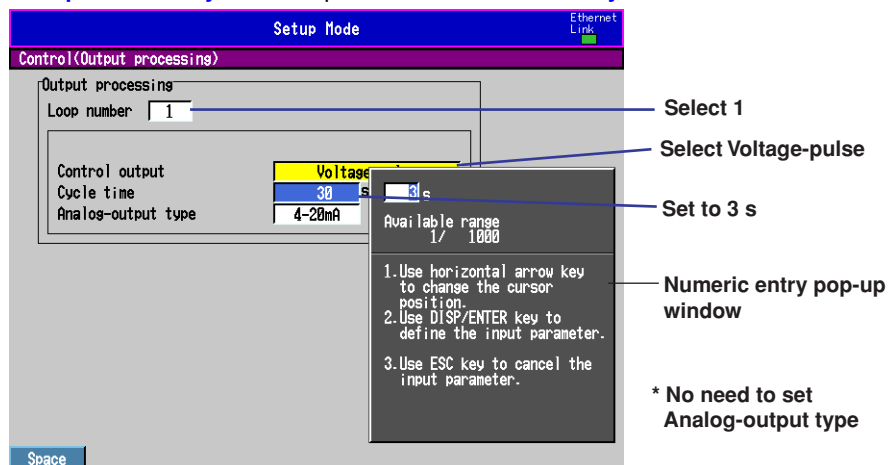

7. Press the **ESC key** twice to return to the menu display (basic setting mode 2/2).
8. Press the **End soft key**.

A confirmation window shown below opens.

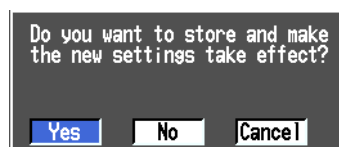

9. Press the **DISP/ENTER key** to confirm the settings.

Setting the Control Input Range in Setting Mode

1. From the operation display, click the **MENU** key to display the control setting menu shown below.

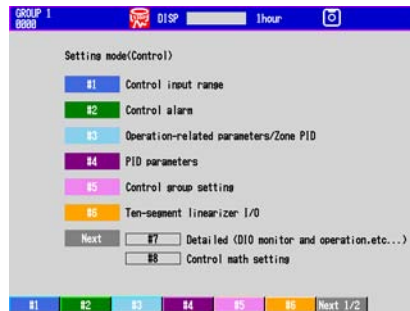

2. Press the **#1** soft key (Control input range).
3. Press the **arrow keys** to move the cursor (blue) to the setup item box, press the **soft key** of each value, and press the **DISP/ENTER** key.

To set the measurement span (span lower/upper-limit, press the **Input** soft key to open a numeric entry pop-up window as shown in the figure below. Enter the value using the **Character/Number** key and the **Space** soft key and then press the **DISP/ENTER** key.

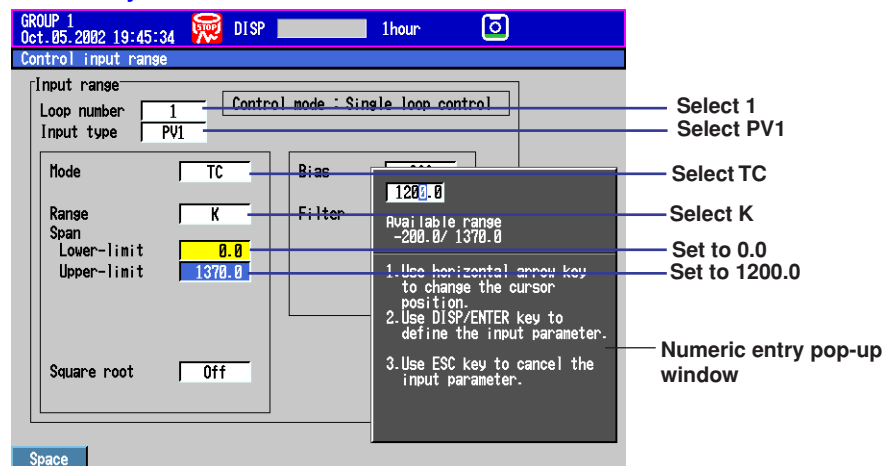

4. Press the **DISP/ENTER** key.
A confirmation window shown below opens.

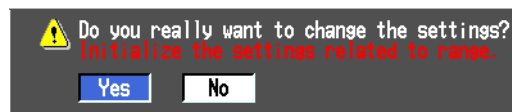

5. Press the **DISP/ENTER** key to confirm the settings.

Setting Control Alarms in Setting Mode

1. From the operation display, click the **MENU key** to display the control setting menu.
2. Press the **#2 soft key** (Control alarm).
3. Press the **arrow keys** to move the cursor (blue) to the setup item box, press the **soft key** of each value according to the following figure.

The numeric value of the alarm is entered using the pop-up window that appears by pressing the **Input soft key**.

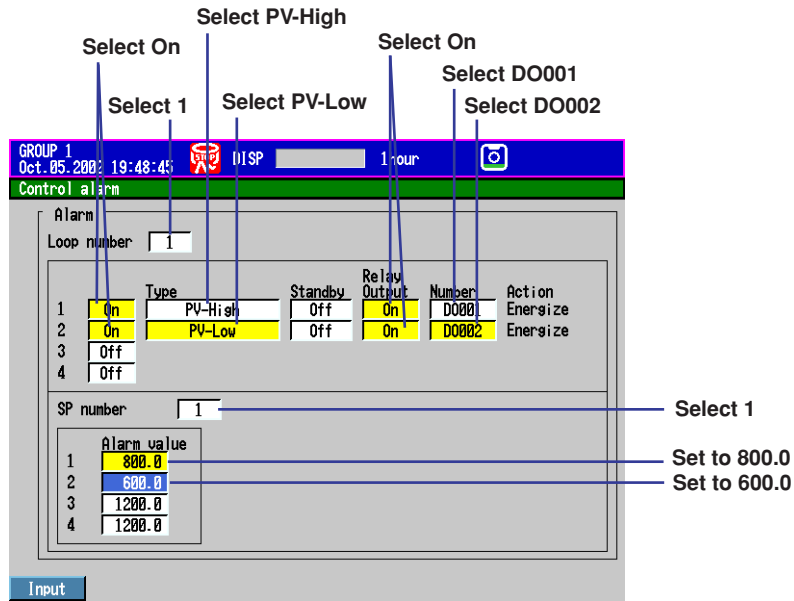

4. Press the **DISP/ENTER key** to confirm the settings.

Setting PID Parameters in Setting Mode

1. From the operation display, click the **MENU key** to display the control setting menu.
2. Press the **#4 soft key** (PID parameters).
3. Press the **arrow keys** to move the cursor (blue) to the setup item box, press the **soft key** of each value according to the following figure.

The numerical values such as the SP are entered using the pop-up window that appears by pressing the **Input soft key**.

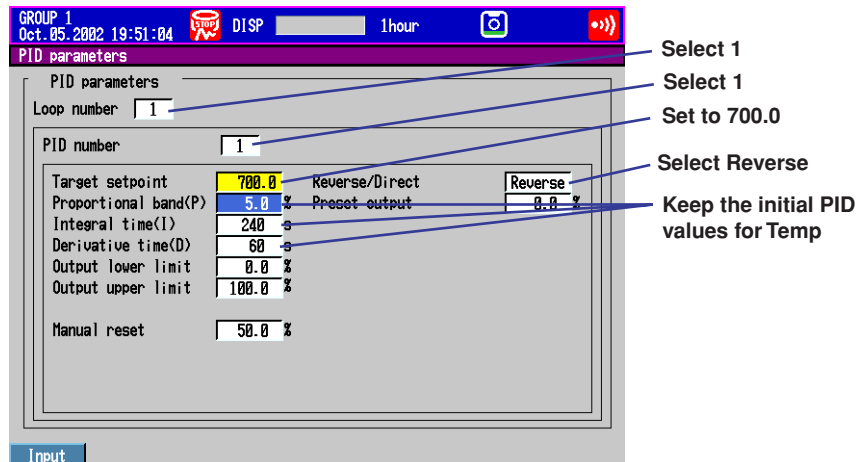

4. Press the **DISP/ENTER key** to confirm the settings.

Control Setup Example 2: Cascade Control

Object of Control and Description

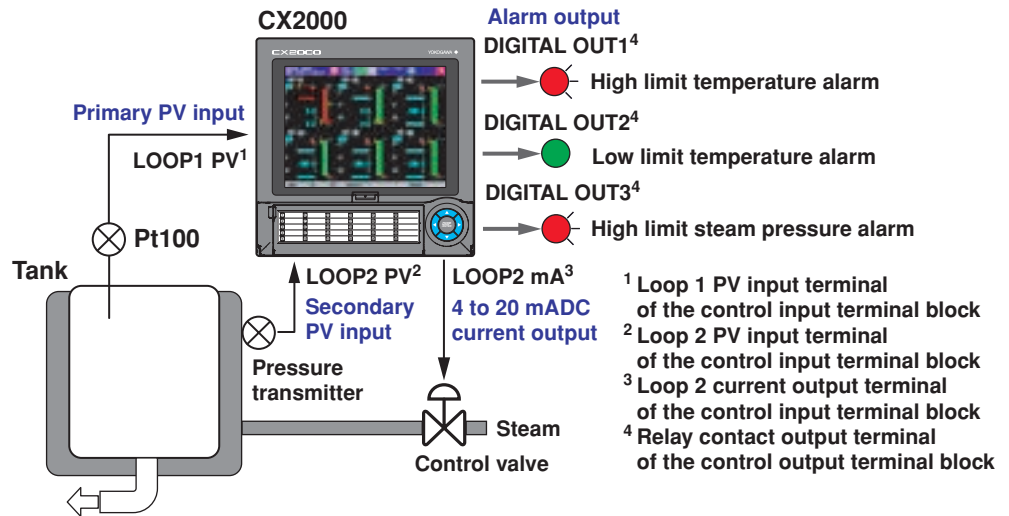

Primary loop of cascade control

- Loop number: 1
- PID constant: P = 20%, I = 300 s, D = 60 s
- Control direction: Reverse
- Input type: RTD Pt100
- Measurement span: 0 to 100°C
- Temperature setpoint: 80°C
- Alarm output: PV high-limit alarm (high limit: 90°C), PV low-limit alarm (low limit: 70°C)

Secondary loop of cascade control

- Loop number: 2
- PID constant: P = 120%, I = 20 s, D = 0 s
- Control direction: Reverse
- Input type: 1-5 V
- Measurement span: 0 to 1.00 MPa
- Output type: Current output (4-20 mA)
- Alarm output: PV high-limit alarm (high limit: 0.90 MPa)

Basic Control Settings

1. Display the basic control setting menu.

See "Control Setup Example 1" for the steps to show the menu.

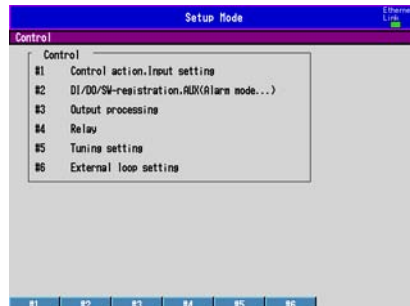

2. Press the **#1 soft key** (Control action, Input setting).
3. Press the **arrow keys** to move the cursor (blue) to the setup item box, press the **soft key** of the value according to the following figure, and press the **DISP/ENTER key**.

Examples of Control Setup Operation

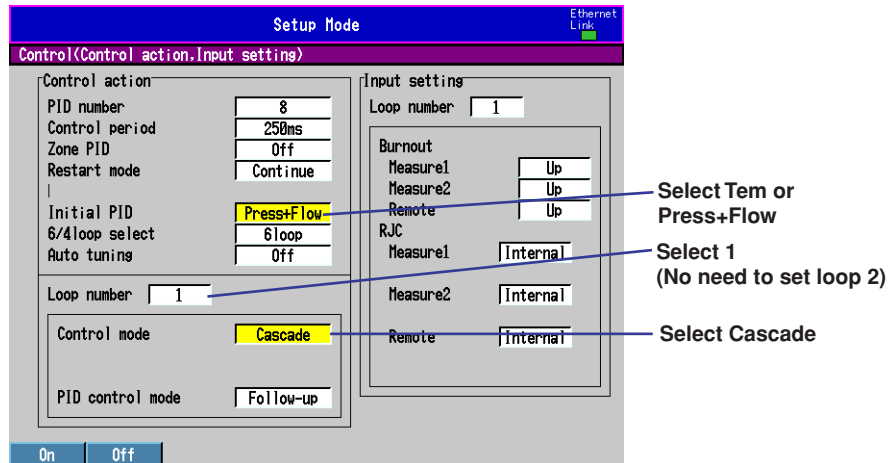

4. Press the **ESC key** to return to the basic control setting menu.
5. Press the **#3 soft key** (Output processing).

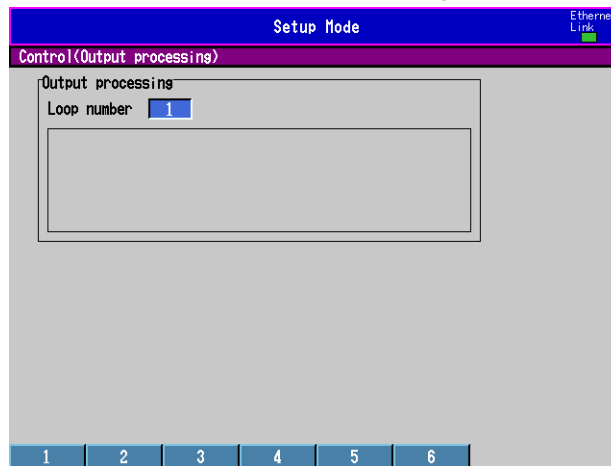

6. Press the **2 soft key**.
There are no control output settings on loop 1 (primary loop of cascade control).
7. Press the **arrow keys** to move the cursor (blue) to the setup item box, press the **soft key** of each value according to the following figure, and press the **DISP/ENTER key**.

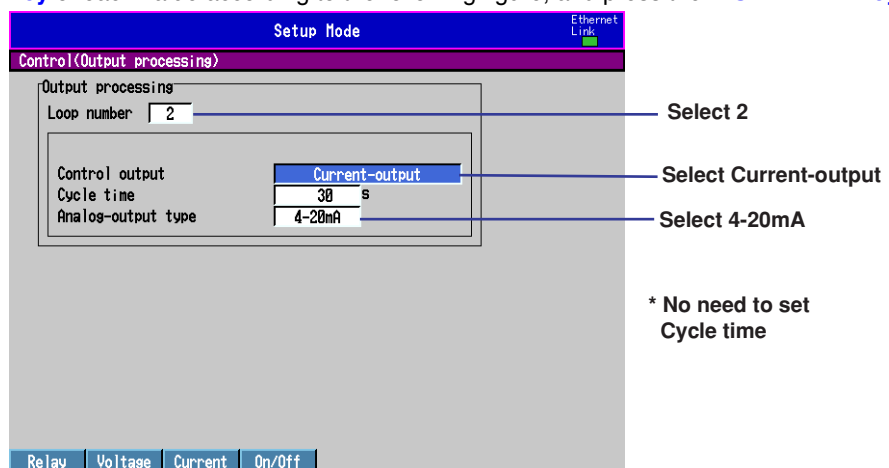

8. Press the **ESC key** twice to return to the menu display (basic setting mode 2/2).

- Press the **End soft key**.
A confirmation window shown below opens.



- Press the **DISP/ENTER key** to confirm the settings.

Setting the Control Input Range in Setting Mode

- From the operation display, click the **MENU key** to display the control setting menu shown below.



- Press the **#1 soft key** (Control input range).
- Press the **arrow keys** to move the cursor (blue) to the setup item box, press the **soft key** of each value according to the following figure.

To set the measurement span (span lower/upper-limit, press the **Input soft key** to open a numeric entry pop-up window as shown in the figure below. Enter the value using the **Character/Number key** and the **Space soft key** and then press the **DISP/ENTER key**.

Setting the Input Range on the Primary Loop of Cascade Control

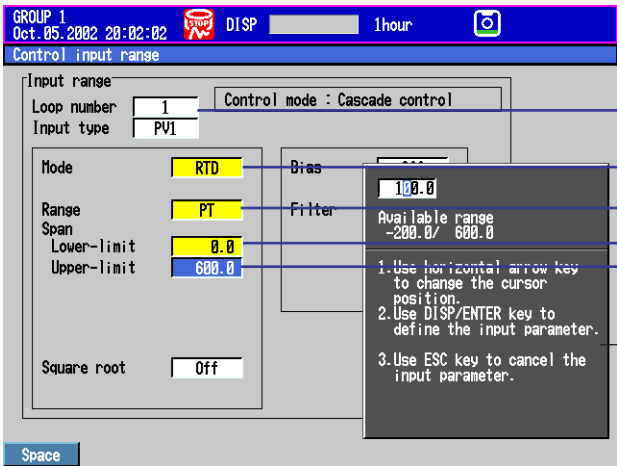

- Select 1
- Select RTD
- Select PT
- Set to 0.0
- Set to 100.0
- Numeric entry pop-up window

- Press the **DISP/ENTER key**.
A confirmation window shown below opens.

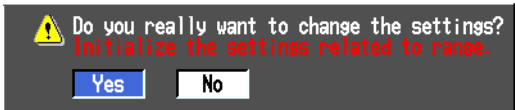

- Press the **DISP/ENTER key** to confirm the settings.

- Set the input range of the secondary loop of cascade control in a similar fashion as described in steps 3 to 5 and according to the figure below.
If you do not carry out steps 4 and 5 and change Loop number, the settings are not saved.

Setting the Input Range on the Secondary Loop of Cascade Control

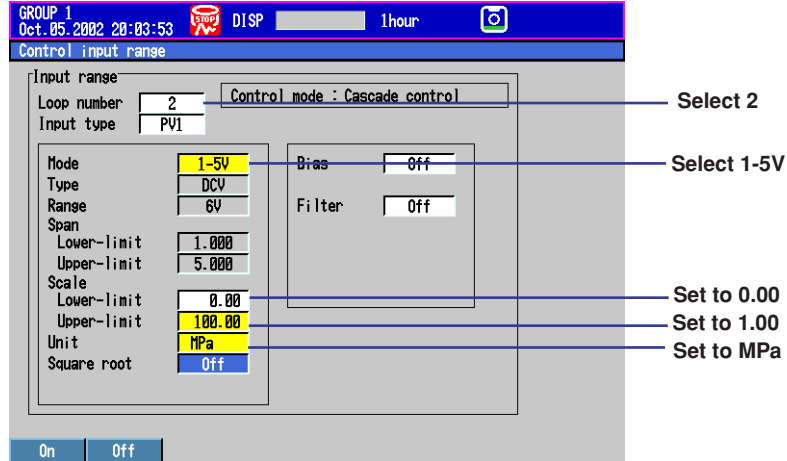

Setting Control Alarms in Setting Mode

- From the operation display, click the **MENU key** to display the control setting menu.
- Press the **#2 soft key** (Control alarm).
- Press the **arrow keys** to move the cursor (blue) to the setup item box, press the **soft key** of each value according to the following figure.
The numeric value of the alarm is entered using the pop-up window that appears by pressing the **Input soft key**.

Setting Alarms on the Primary Loop of Cascade Control

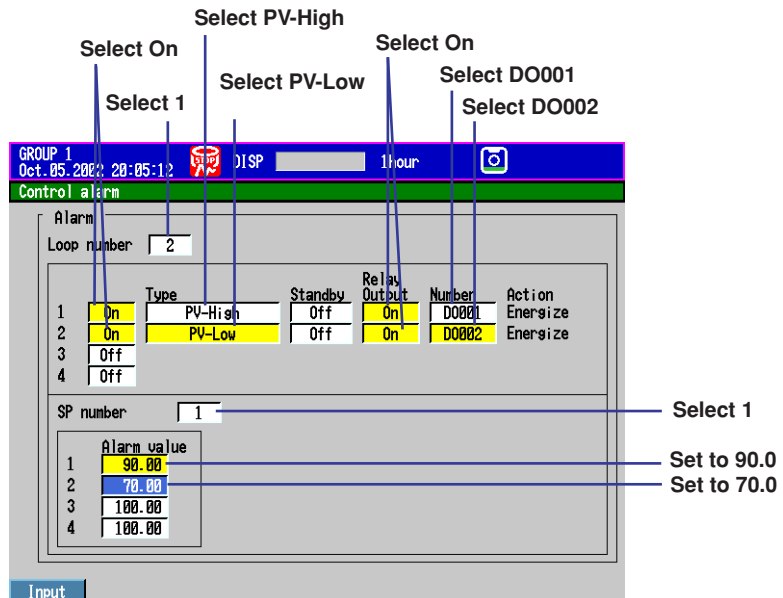

- Press the **DISP/ENTER key** to confirm the settings.
- Set the alarms of the secondary loop of cascade control in a similar fashion as described in steps 3 and 4 and according to the figure on the next page.
If you do not carry out step 4 and change Loop number, the settings are not saved.

Setting Alarms on the Secondary Loop of Cascade Control

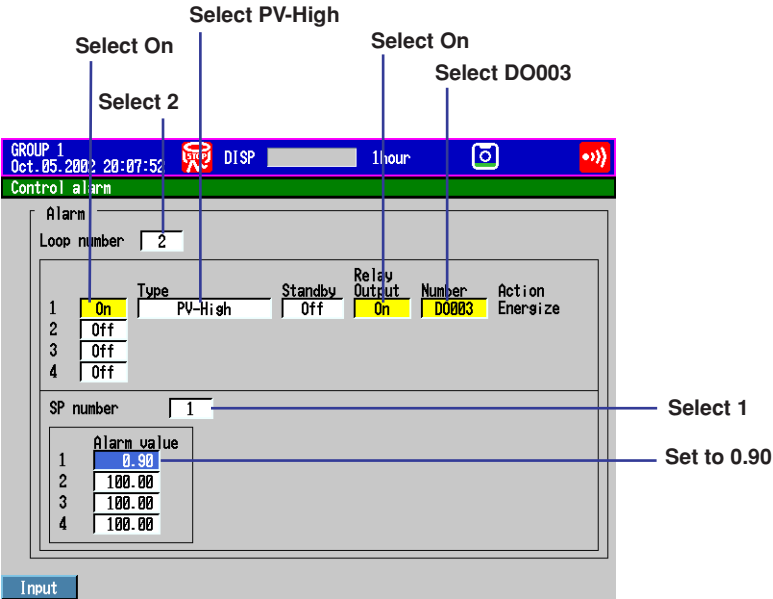

Setting PID Parameters in Setting Mode

1. From the operation display, click the **MENU** key to display the control setting menu.
2. Press the **#4 soft key** (PID parameters).
3. Press the **arrow keys** to move the cursor (blue) to the setup item box, press the **soft key** of each value according to the following figure.

The numerical values such as the SP are entered using the pop-up window that appears by pressing the **Input soft key**.

Setting PID Parameters on the Primary Loop of Cascade Control

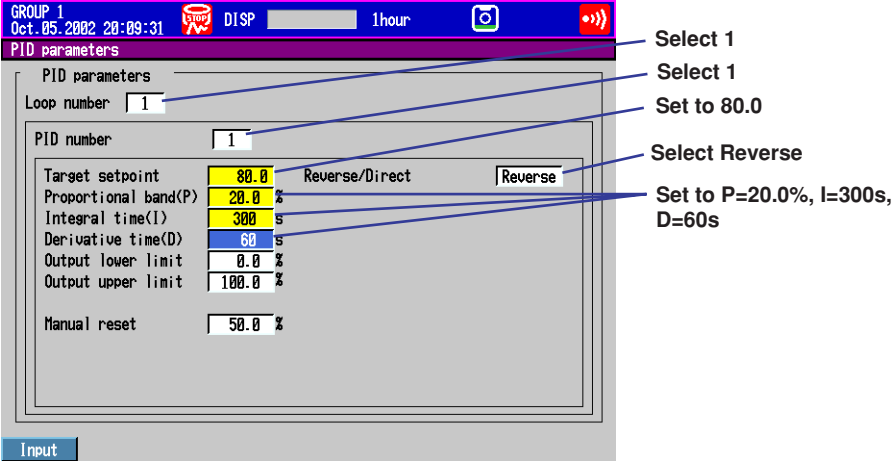

4. Press the **DISP/ENTER** key to confirm the settings.
5. Set the PID parameters of the secondary loop of cascade control in a similar fashion as described in steps 3 and 4 and according to the figure on the next page. If you do not carry out step 4 and change Loop number, the settings are not saved.

Setting PID Parameters on the Secondary Loop of Cascade Control

GROUP 1
Oct. 05. 2002 20:10:21 DISP 1hour

PID parameters

PID parameters

Loop number: 2

PID number: 1

Target setpoint	0.00	Reverse/Direct	Reverse
Proportional band(P)	120.0 %	Preset output	0.0 %
Integral time(I)	20 s		
Derivative time(D)	0 s		
Output lower limit	0.0 %		
Output upper limit	100.0 %		
Shutdown	Off		
Manual reset	50.0 %		

1 2 3 4 5 6

Select 2
Select 1
Select Reverse
Set to P=120.0% I=20 s, D=0 s
(No need to change the settings if the initial PID values are set for Press+Flow)

Control Setup Example 3: Loop Control with PV Switching

Object of Control and Description

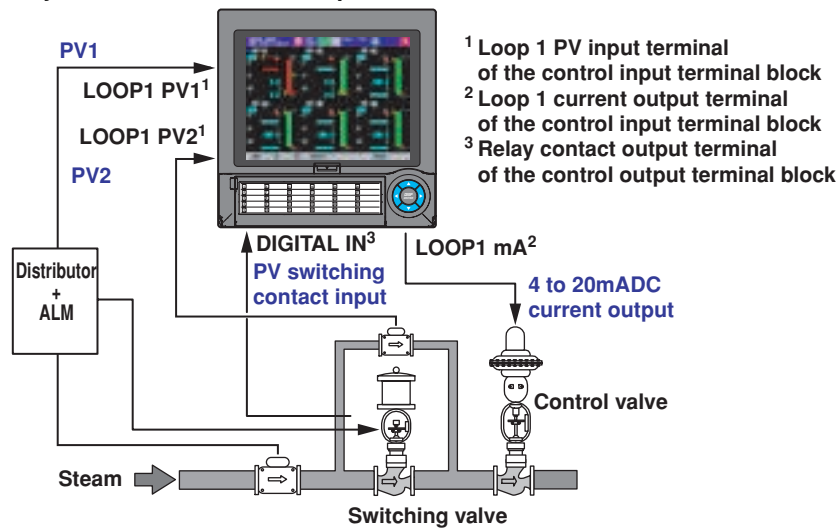

- Loop number: 1
- PID constant: P = 120%, I = 20 s, D = 0 s
- Control direction: Reverse
- Input type: 1-5 V for both measurement input 1 and 2
- Measurement span: PV input 1: 0 to 300 kg/h, PV input 2: 0 to 30 kg/h
- PV range conversion: Lower limit: 0 kg/h, Upper limit: 300 kg/h
- Flow rate setpoint: 100 kg/h
- Input switching condition: Contact input

Basic Control Settings

1. Show the show the basic control setting menu.
See "Control Setup Example 1" for the steps to show the menu.

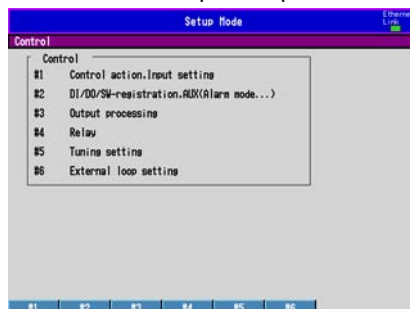

2. Press the **#1 soft key** (Control action, Input setting).
3. Press the **arrow keys** to move the cursor (blue) to the setup item box, press the **soft key** of each value according to the following figure, and press the **DISP/ENTER key**.

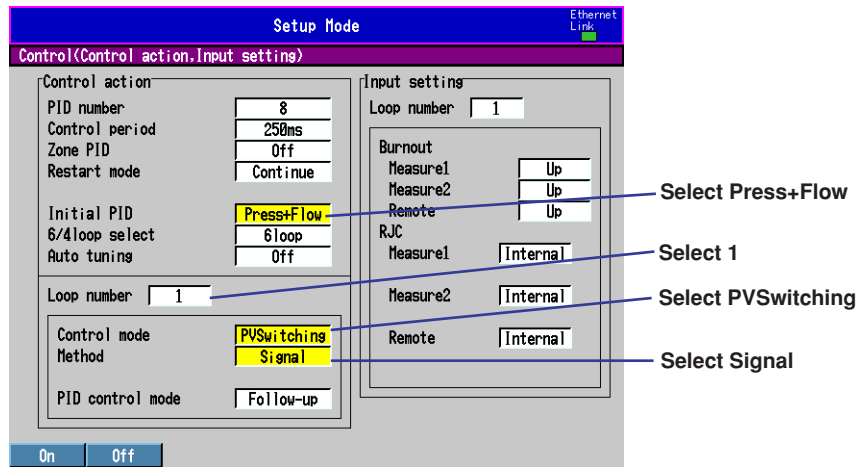

4. Press the **ESC key** to return to the basic control setting menu.
5. Press the **#3 soft key** (Output processing).
6. Press the **arrow keys** to move the cursor (blue) to the setup item box, press the **soft key** of each value according to the following figure, and press the **DISP/ENTER key**.

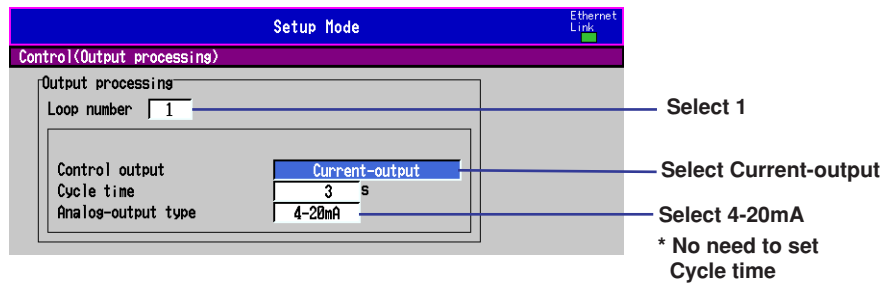

7. Press the **ESC key** twice to return to the menu display (basic setting mode 2/2).
8. Press the **End soft key**.

A confirmation window shown below opens.



9. Press the **DISP/ENTER key** to confirm the settings.

Setting the Control Input Range in Setting Mode

1. From the operation display, click the **MENU key** to display the control setting menu shown below.



2. Press the **#1 soft key** (Control input range).

Examples of Control Setup Operation

- Press the **arrow keys** to move the cursor (blue) to the Input type box, press the **PV1 soft key**, and set other parameters as shown in the figure below.

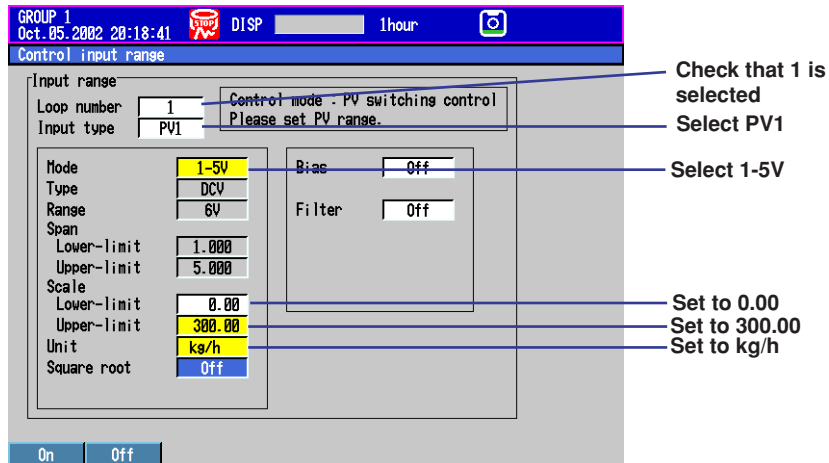

- Press the **DISP/ENTER key**.
A confirmation window opens.
- Press the **DISP/ENTER key** to confirm the settings.
- Press the **arrow keys** to move the cursor (blue) to the Input type box, press the **PV2 soft key**, and set other parameters as shown in the figure below.

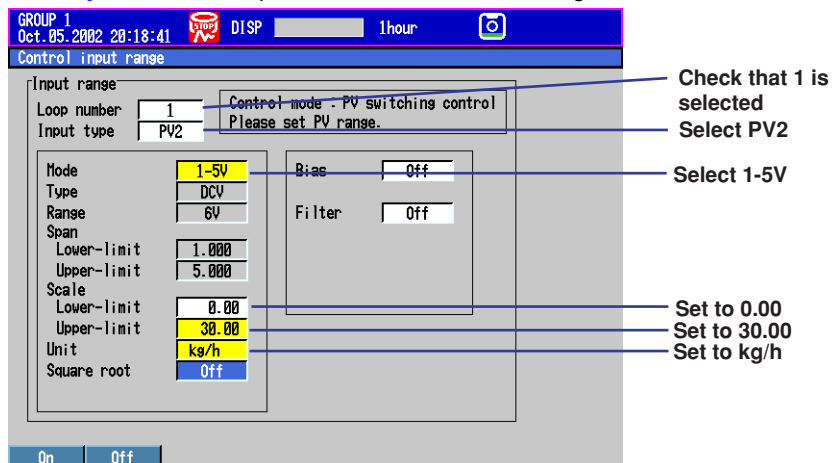

- Press the **DISP/ENTER key**.
A confirmation window opens.
- Press the **DISP/ENTER key** to confirm the settings.
- Press the **arrow keys** to move the cursor (blue) to the Input type box, press the **PVrange soft key**, and set other parameters as shown in the figure below.

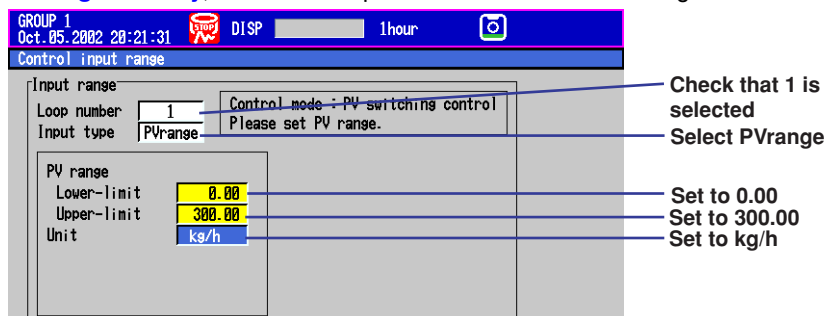

- Press the **DISP/ENTER key**.
A confirmation window opens.
- Press the **DISP/ENTER key** to confirm the settings.

Setting PID Parameters in Setting Mode

1. From the operation display, click the **MENU** key to display the control setting menu.
2. Press the **#4** soft key (PID parameters).
3. Press the **arrow keys** to move the cursor (blue) to the setup item box, press the **soft key** of each value according to the following figure.

The numerical values such as the SP are entered using the pop-up window that appears by pressing the **Input** soft key.

Select 1
 Select 1
 Set to 100.0
 Select Reverse
 Set to P=120.0%, I=20 s, D=0 s (No need to change the settings if the initial PID values are set for Press+Flow)

4. Press the **DISP/ENTER** key to confirm the settings.

Control Setup Example 4: ON/OFF Control

Object of Control and Description

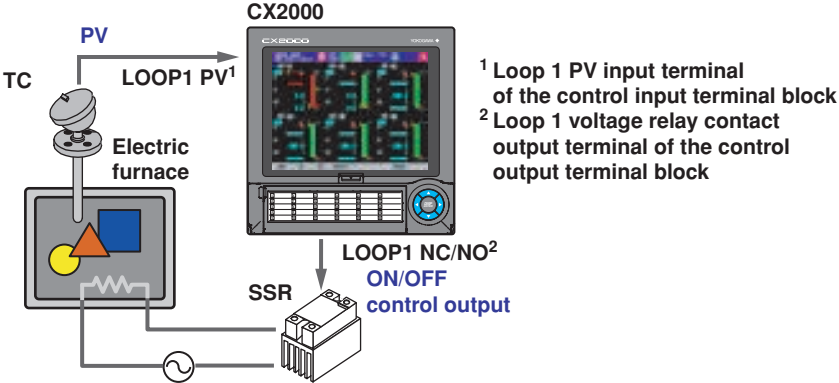

- Loop number: 1
- Control direction: Reverse
- Relay hysteresis Setpoint: 10.0, activation position: center
- Input type: TC K type
- Measurement span: 0 to 1200°C
- Output type: ON/OFF control output
- Temperature setpoint: 700°C

Basic Control Settings

1. Show the basic control setting menu.
 See "Control Setup Example 1" for the steps to show the menu.

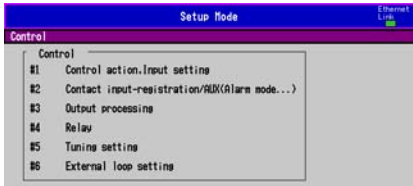

Examples of Control Setup Operation

2. Press the **#1 soft key** (Control action, Input setting).
3. Press the **arrow keys** to move the cursor (blue) to the setup item box, press the **soft key** of each value according to the following figure, and press the **DISP/ENTER key**.

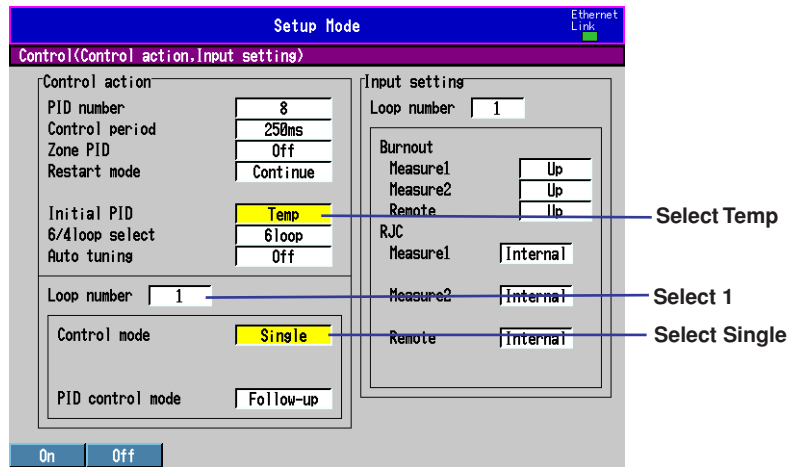

4. Press the **ESC key** to return to the basic control setting menu.
5. Press the **#3 soft key** (Output processing).
6. Press the **arrow keys** to move the cursor (blue) to the setup item box, press the **soft key** of each value according to the following figure, and press the **DISP/ENTER key**.

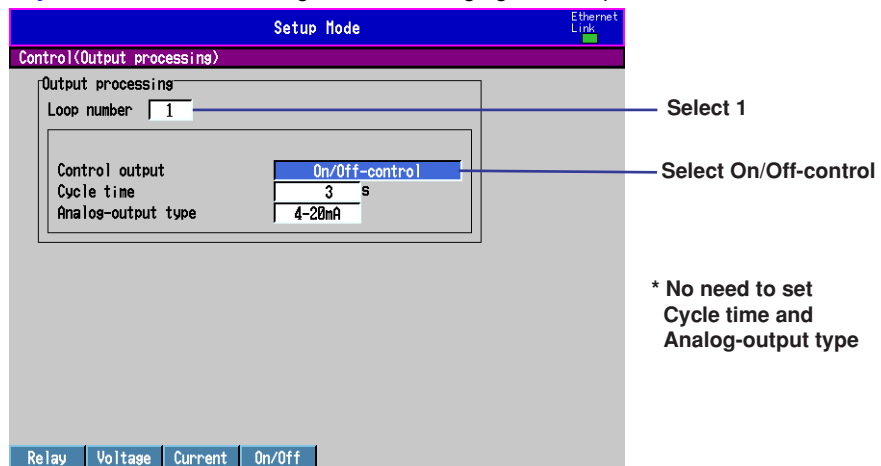

7. Press the **ESC key** twice to return to the menu display (basic setting mode 2/2).
8. Press the **End soft key**.
A window appears for you to confirm the saving of the new settings.
9. Press the **DISP/ENTER key** to confirm the settings.

Setting the Control Input Range in Setting Mode

1. From the operation display, click the **MENU key** to display the control setting menu shown below.



2. Press the **#1 soft key** (Control input range).
3. Press the **arrow keys** to move the cursor (blue) to the setup item box, press the **soft key** of each value according to the following figure.

The numeric values of the lower/upper limit of range are entered using the pop-up window that appears by pressing the **Input soft key**.

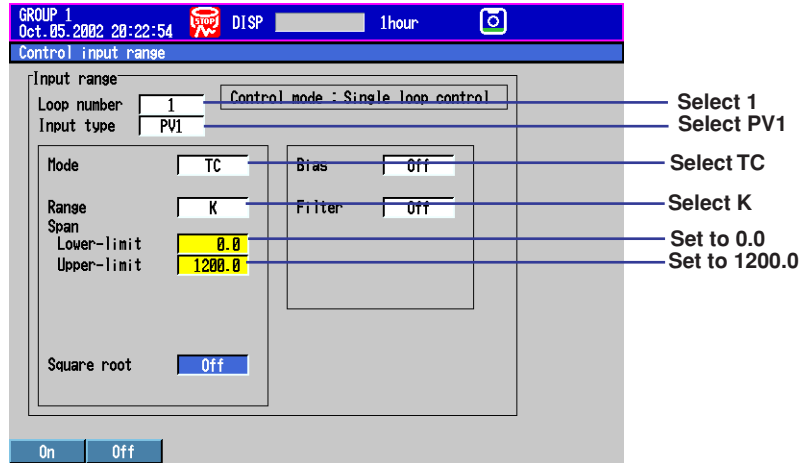

4. Press the **DISP/ENTER key**.
A confirmation window shown below opens.

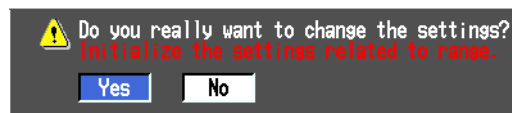

5. Press the **DISP/ENTER key** to confirm the settings.

Setting Control Parameters in Setting Mode

1. From the operation display, click the **MENU key** to display the control setting menu.
2. Press the **#4 soft key** (PID parameters).
3. Press the **arrow keys** to move the cursor (blue) to the setup item box, press the **soft key** of each value according to the following figure.

The numeric values of the target setpoint and relay hysteresis setpoint are entered using the pop-up window that appears by pressing the **Input soft key**.

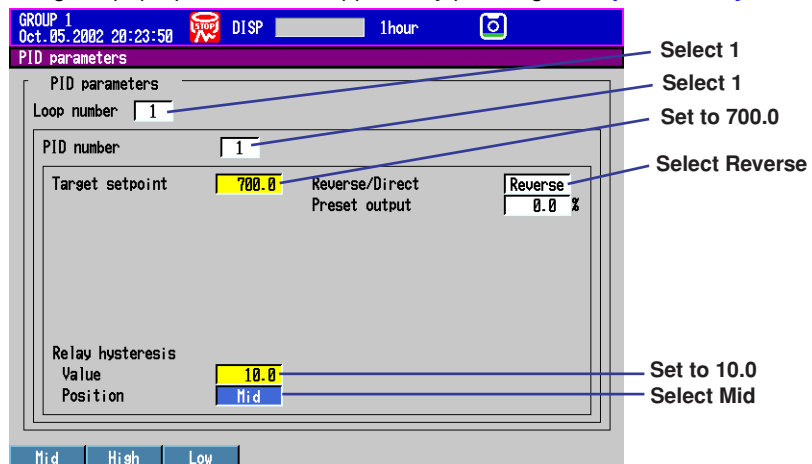

4. Press the **DISP/ENTER key** to confirm the settings.

Setting the Display Items on the Control Group Display (Control Group Setting)

Below are the procedures for displaying loops 1 to 5 and measurement channel (input channel for measurement) 1 on the control group display (group name: CONTROL GROUP 1) of group number 1.

1. From the operation display, click the **MENU key** to display the control setting menu shown below.

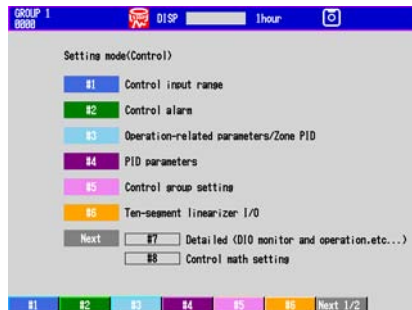

2. Press the **#5 soft key** to show the Control group setting display.
3. Press the **arrow keys** to move the cursor (blue) to the setup item box, press the **soft key** of each value according to the following figure.

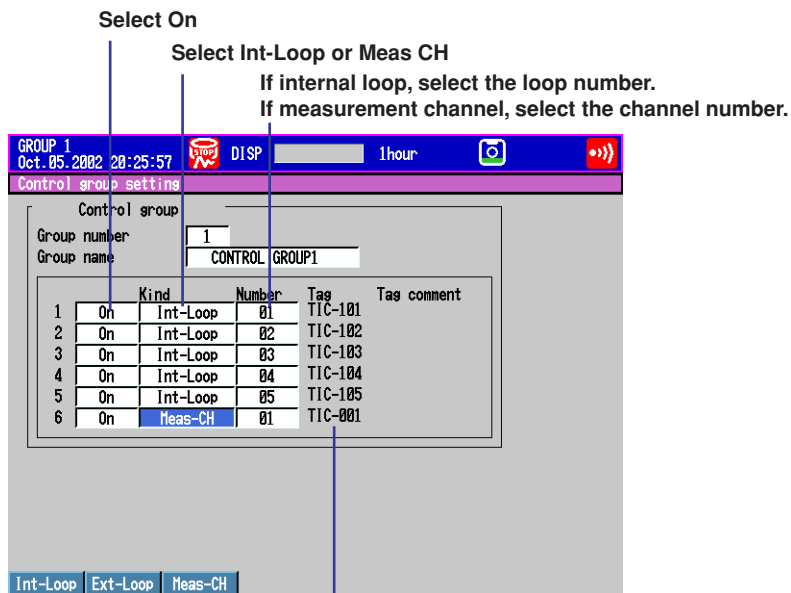

Tag display
(Tag is set using the #3 Operation related/zone PID setting display)

4. Press the **DISP/ENTER key** to confirm the entry.

Control Group Display Example after Setup

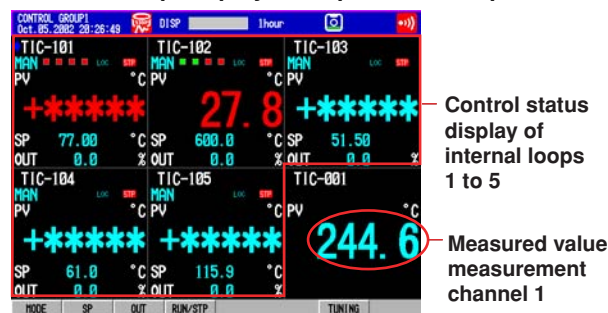

Displaying the Trend of PV, SP, and OUT Values

Below are the procedures for displaying the trends of PV, SP, and OUT of loop 1 on the trend display of group number 1 (group name: GROUP 1).

1. From the operation display, open the Group set, Trip line setting display according to the following procedure.

Press the **MENU key** (to switch to Setting mode (Control)) and then the **MENU key** (switch to Set mode). Press the **#4 soft key** (to select Display) and then the **#1 soft key** (to select Group set, Trip line).

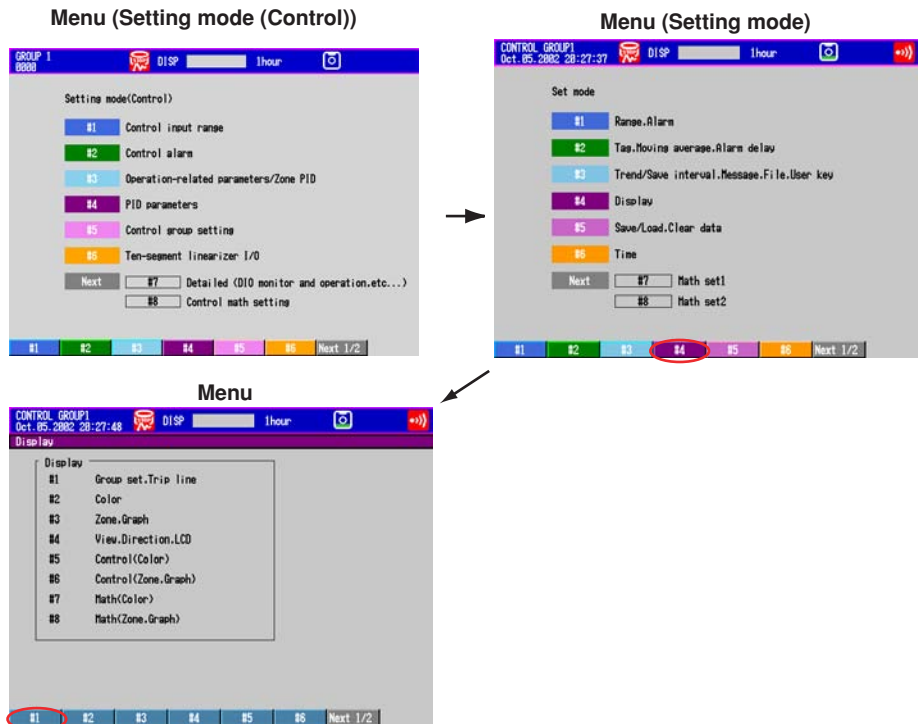

2. Press the **arrow keys** to move the cursor (blue) to the Channel setting box.
3. Press the **Input soft key** to open the channel input pop-up window.
4. Use the **Character/Number key** and **soft keys** to select the channels to include in the group.

In this group setting, the PV, SP, and OUT of loop 1 are assigned channel numbers 101, 102, and 103, respectively. To include PV, SP, and OUT of loop 1, enter 101-103 or 101.102.103.

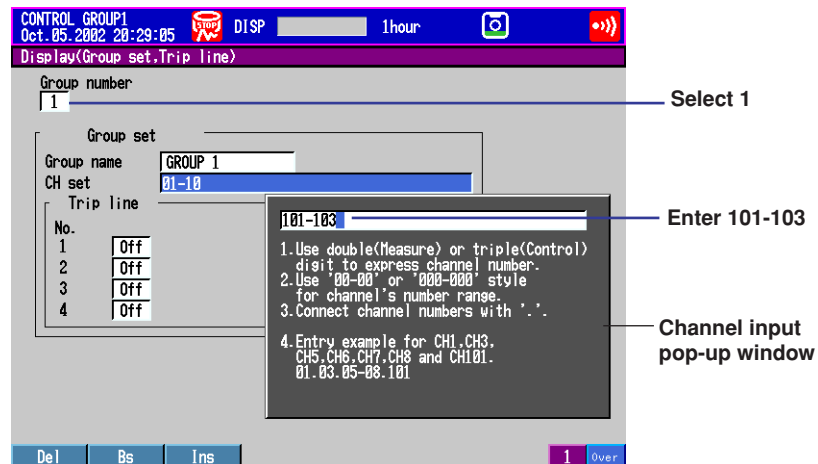

5. Press the **DISP/ENTER key** to confirm the entry.

Displaying the Trend of PV, SP, and OUT Values

Note

You can select up to 10 channels from measurement channels (CH1 to CH20), computation channels (CH31 to CH60), internal control channels (CH101 to CH118), and external control channels (CH201 to CH248) using Channel setting.

- Assignment of internal control channels (channels of internal loops)

The data of 6 loops is assigned to channel numbers as follows:

Loop 1 PV: 101, Loop 1 SP: 102, Loop 1 OUT: 103

...

Loop 6 PV: 116, Loop 6 SP: 117, Loop 6 OUT: 118

- Assignment of external control channels (channels of external loops)

The data of 16 loops is assigned to channel numbers as follows:

External loop 1 PV: 201, External loop 1 SP: 202, External loop 1 OUT: 203

...

External loop 16 PV: 246, External loop 16 SP: 247, External loop 16 OUT: 248

Set the channels to assign them to a group according to the following rules.

- Enter the channel number using two or three digits.
- Separate each channel with a period.
- Use a hyphen to specify consecutive channels.

Example: To assign CH1, CH3, CH5 to CH8, and CH101, enter 01.03.05-08.101.

Trend Display Example after Setup

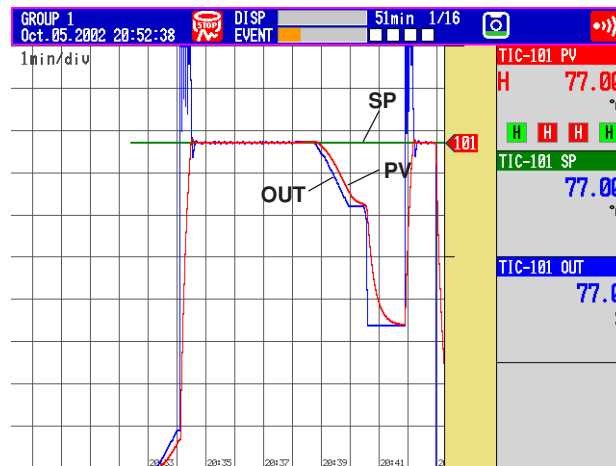

Switching the Operation Mode

For details on the procedure for switching the operation mode, see chapter 6, “Operations during Control Operation” in the *CX2000 User’s Manual (IM 04L31A01-01E)*. The following is a procedural example on the control group display.

Run/Stop Operation

For cascade control, the following operations can be performed only when the secondary loop is selected.

1. Use the **arrow keys** to move the cursor to the desired control loop.

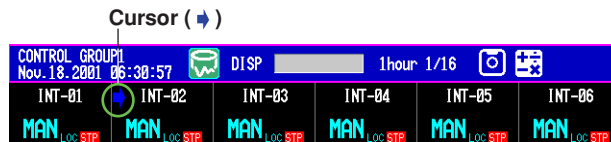

2. Press the **RUN/STP soft key**.

A pop-up window for running and stopping the operation appears.



Window for starting and stopping operation

3. Select RUN or STOP using the **up and down arrow keys**.
4. Press the **DISP/ENTER key** to confirm the changes.

Switching between Auto, Manual, and Cascade Control

You can only switch to the cascade mode on the secondary loop of cascade control.

1. Use the **arrow keys** to move the cursor to the desired control loop.
2. Press the **Mode soft key**.

The MODE selection pop-up window appears.

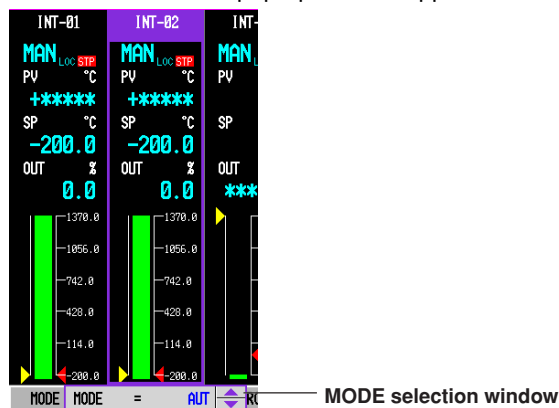

MODE selection window

3. Select AUT (auto), MAN (manual), or CAS (cascade) using the **up and down arrow keys**.
4. Press the **DISP/ENTER key** to confirm the changes.

Changing the Target Setpoint

1. Use the **arrow keys** to move the cursor to the desired control loop.
2. Press the **SP soft key**.

The SP modification pop-up window appears. The window shows the current target setpoint.

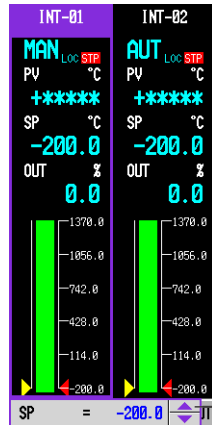

Window for changing the target setpoint

3. Change the target setpoint using the **up and down arrow keys**.
4. Press the **DISP/ENTER key** to confirm the changes.

Changing the Control Output

The following operation cannot be performed during auto operation, when operation is stopped, or when the primary loop of cascade control is selected. When the operation is stopped, the preset value is output.

1. Use the **arrow keys** to move the cursor to the desired control loop.
2. Press the **OUT soft key**.

The OUT modification pop-up window appears. The window shows the current control output.

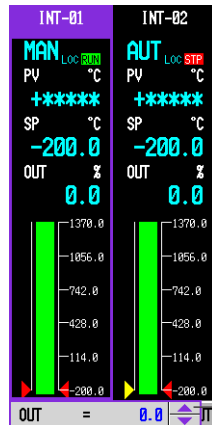

Window for changing the control output

3. Change the control output using the **up and down arrow keys**.
The control output is set to the new value at this point.
4. Press the **DISP/ENTER key** to complete the procedure.

Switching between Remote and Local Modes

The soft key menu does not show REM/LOC, if Control > Contact input-registration/ AUX(Alarm mode... > Remote setting is set to Off. Remote input cannot be used for the target setpoint when the secondary loop of cascade control is selected or during program control. Thus, there is no remote/local switching in these cases.

1. Use the **arrow keys** to move the cursor to the desired control loop.
2. Press the **REM/LOC soft key**.

A pop-up window for switching between remote and local appears.

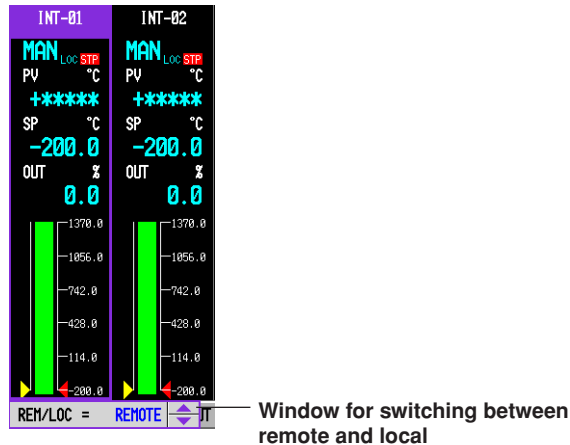

3. Select REMOTE or LOCAL using the **up and down arrow keys**.
4. Press the **DISP/ENTER key** to confirm the changes.

Switching between Automatic and Manual for the Analog Retransmission Loop

You can switch the output mode for the control loop specified for analog retransmission. When set to AUTO, the computed result of analog retransmission is output. When set to MAN, you can set the direct output value.

1. Use the **arrow keys** to move the cursor to the desired control loop.
2. Press the **MODE soft key**.

A pop-up window switching between auto and manual appears.

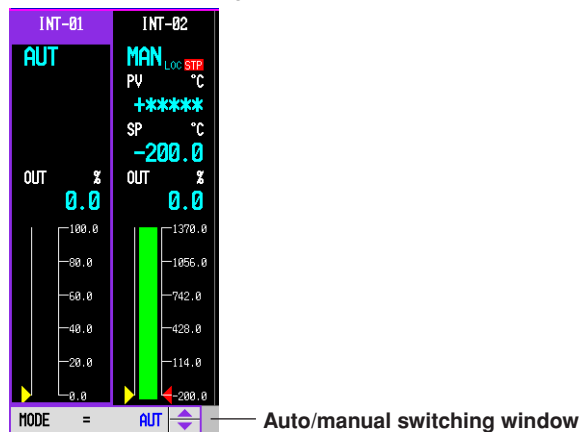

3. Select AUTO or MAN using the **up and down arrow keys**.
4. Press the **DISP/ENTER key** to confirm the changes.

Changing the Analog Retransmission Output

MAN must be set for the MODE using the procedure above.

1. Use the **arrow keys** to move the cursor to the desired control loop
2. Press the **OUT soft key**. The Output Value Setting window appears.

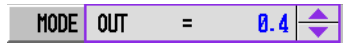

3. Change the output value using the **up and down arrow keys**. The currently set control output value is displayed in the window.

Switching between Automatic and Manual for the DIO Operation Monitoring

You can switch the output mode for the DO specified in the DIO Operation Monitoring Function. When set to AUTO, the internal switch status is output. When set to MAN, you can switch the direct output value between 0 and 1.

1. Use the **arrow keys** to move the cursor to the desired control loop.
2. Press the **MODE soft key**.

A pop-up window switching between auto and manual appears.

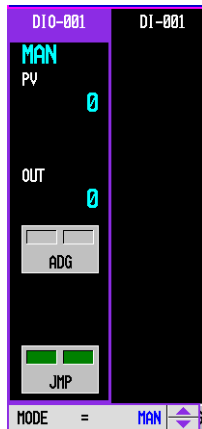

Auto/manual switching window

3. Select AUTO or MAN using the **up and down arrow keys**.
4. Press the **DISP/ENTER key** to confirm the changes.

Changing the DO Output for the DIO Operation Monitoring

MAN must be set for the MODE using the procedure above.

1. Use the **arrow keys** to move the cursor to the desired control loop
2. Press the **OUT soft key**. The Output Value Setting window appears.

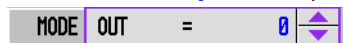

3. Change the output value using the **up and down arrow keys**. The currently set control output value is displayed in the window.

Tuning Operation

For details on the procedure of switching the operation mode, see chapter 6, “Operations during Control Operation” in the *CX2000 User's Manual (IM 04L31A01-01E)*.

Displaying the Tuning Display

Press the **TUNING soft key** on the control group display.

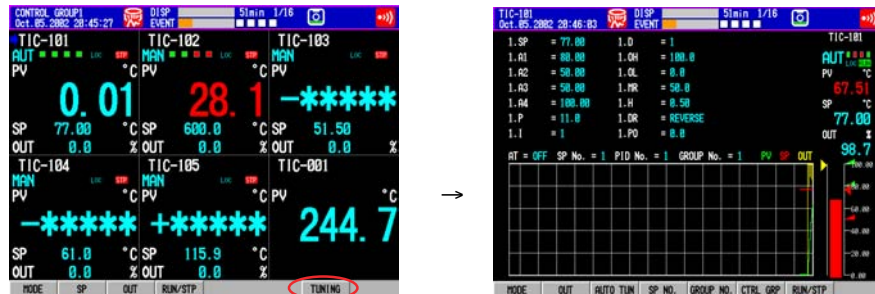

Auto Tuning

To execute auto tuning, Basic setting mode > #10 Control > #1 Control action, Input setting > Auto tuning must be turned On before carrying out the following procedure.

1. Press the **AUTO TUN soft key** on the tuning display.

As shown in the following figure, the auto tuning setup pop-up window appears along with a warning message.

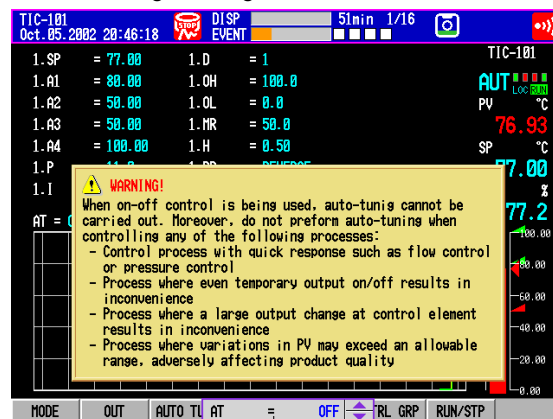

Auto tuning setup window

2. Select the control loop using the **up and down arrow keys**.

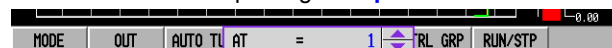

3. Press the **DISP/ENTER key** to execute auto tuning.

CAUTION

- You cannot execute auto tuning during ON/OFF control.
- Do not execute auto tuning when controlling the following types of processes. If you do, malfunction may occur in the control process.
 - Control process with fast response such as flow control and pressure control.
 - Processes that result in adverse consequences when the output is turned on/off even if temporarily.
 - Processes that result in adverse consequences if a large output change is applied to the control element.
 - Processes that may cause adverse effects on the quality of a product when the process value exceeds the allowed fluctuation width.

Manual Tuning

1. Press the **arrow keys** on the tuning display.
A cursor appears in the control parameter display section.
2. Select the control parameter you wish to change using the **arrow keys**.
3. Press the **DISP/ENTER key**.
The parameter modification pop-up window appears.

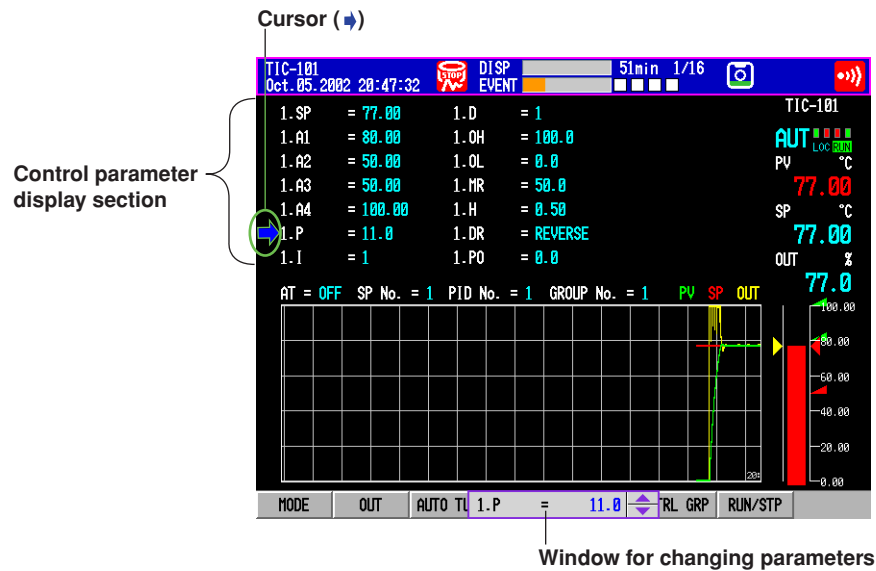

4. Change the value using the **up and down arrow keys**.
5. Press the **DISP/ENTER key** to confirm the changes.
To close the window without making any changes, press the **ESC key**.

Program Control Function (/PG1 and /PG2 Options)

Program Control Function Introduction

Program control function is used to ramp-up or ramp-down the SP according to a program pattern. The number of program patterns that you can create with the CX2000 is as follows:

- /PG1 option: 4
- /PG2 option: 30

Up to 99 segments can be specified in a single pattern.

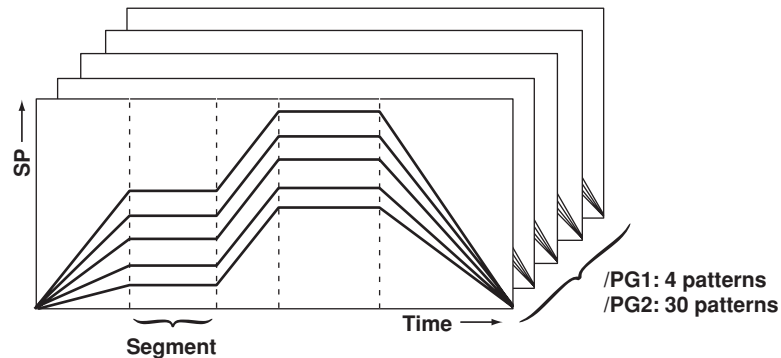

Operation Mode during Program Control

The following 4 types of operation modes are available.

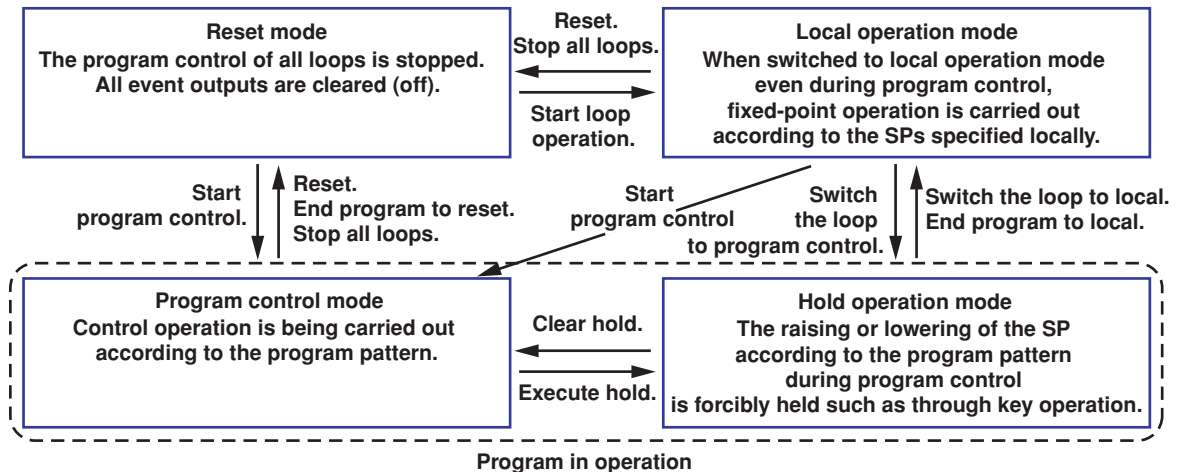

Operations on the Program Selection Display (See the figure on the next page)

Displaying the Program Selection Display

On the control group display or control overview display, select **CONTROL** > **PROGRAM** from the screen selection menu.

Starting Program Control

Program control starts, and the screen switches to the Program Control Display.

1. On the Program Selection Display, press the **RUN** soft key.

A pop-up window for starting the program control appears.



2. Press the **DISP/ENTER** key.

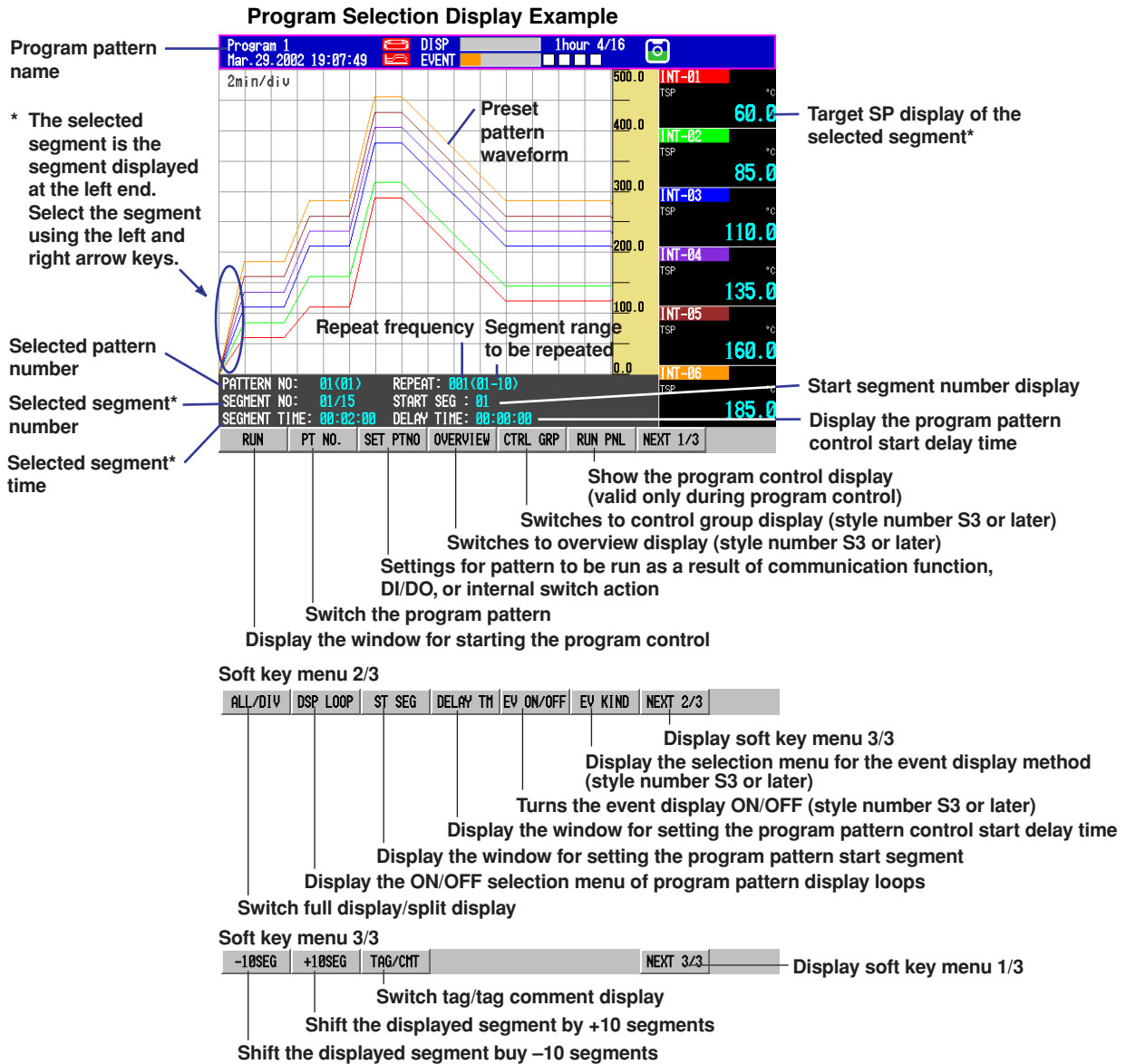

Operations on the Program Control Display (See the figure on the next page)

Displaying the Program Control Display

When you start the program control on the program selection display, the program control display appears. You can display the program control display when program control is in progress by selecting **CONTROL > PROGRAM** from the display selection menu on the control group display or the control overview display or pressing the **RUN PNL soft key** on the program selection display.

Executing and Clearing the Hold Operation

You can hold the progress of the program (stop the timer). While in hold, you can change the segment SP or increase or decrease the remaining segment time.

1. Press the **HOLD soft key**.

A pop-up window for executing/clearing the hold operation appears.

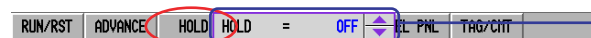

Window for executing/clearing the hold operation.

2. Select [ON] (execute) or [OFF] (clear) using the **up and down arrow keys**.
3. Press the **DISP/ENTER key**.

Resetting Program Control

Resets the program control and stops.

1. Press the **RUN/RST soft key**.

A pop-up window for starting and resetting program control appears.



2. Select [RESET] using the **up and down arrow keys**.
3. Press the **DISP/ENTER key**.

Program Control Display Example

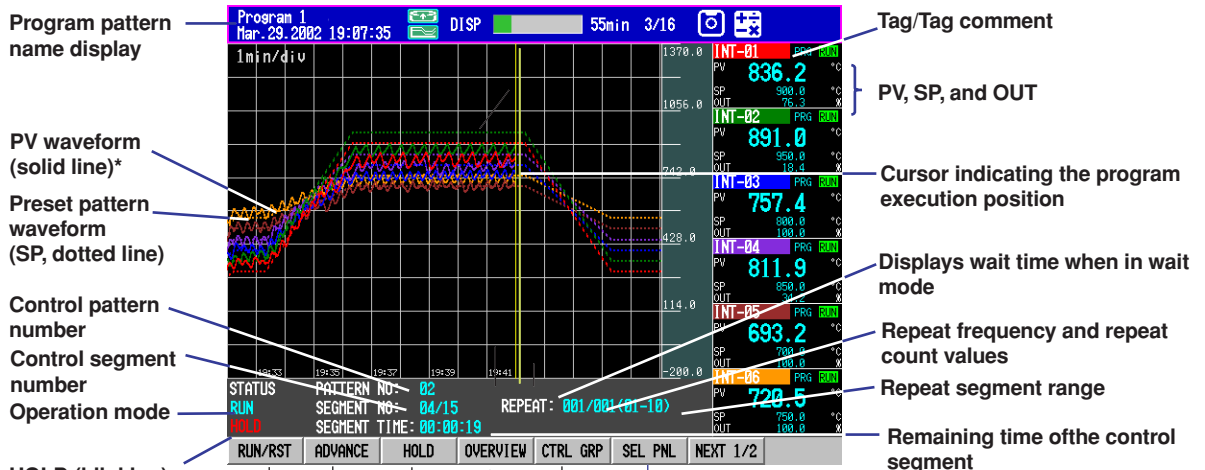

- HOLD (blinking):** Hold mode
- WAIT:** Wait mode
- DELAY:** Program pattern control being delayed
- RUN/RST:** Display the window for starting program control and resetting
- ADVANCE:** Advance the program
- HOLD:** Hold the program
- OVERVIEW:** Switch to overview display (style number S3 or later)
- CTRL GRP:** Switch to control group display (style number S3 or later)
- SEL PNL:** Show the program selection display
- NEXT 1/2:** Next screen

* PV waveforms are displayed when you press the START key to start the data acquisition to the internal memory.

Soft key menu 2/2

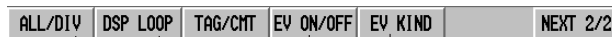

- ALL/DIV:** Switch full display/split display
- DSP LOOP:** Display the ON/OFF selection menu of program pattern display loops
- TAG/CMT:** Switch tag/tag comment display
- EV ON/OFF:** Turn the event display ON/OFF (style number S3 or later)
- EV KIND:** Display the selection menu for the event display method (style number S3 or later)

Soft key menu when in hold mode



- SEG TIME:** Display the window for changing the remaining segment time
- TSP CHG:** Display the menu for selecting the loop of which the target SP is to be changed



Switching between Program Control and Local Control for Each Loop

Press the **PRG/LOC soft key** on the control group screen to switch between program and local.

Executing Several Program Patterns

You can execute multiple program patterns whose loop numbers do not overlap.

Switching Pattern Numbers

1. Press the **PT NO. soft key** in the program selection screen.
The pattern number switching pop-up window appears. The currently set pattern numbers are displayed in the window.
2. Select a pattern number using the up and down arrow keys.
3. Press **DISP/ENTER key** to confirm the changed settings.
To close without saving, press the **ESC key**.

Program Operation Start

1. Press the **RUN soft key**.
The program operation start pop-up window appears.
2. Press the **DISP/ENTER key**. The screen changes to the program operation display.

Displaying the Program Selection Display

1. Press the **SEL PNL soft key**.
The screen changes to the program selection display.

Executing a Separate Program Pattern

1. Repeat the above procedure as necessary.

Switching the Displayed Pattern in the Program Operation Display

1. Press the **left or right arrow keys** to switch the displayed pattern.

Program Control Setup Operation

Program Control Setup Operation Sequence

First, set the control functions of the loops to be used (see below). Next, set the program control (see page 39).

Setting the Control Operation of the Loops to Be Used

This section explains only the settings specific to the program control.

- **Control > Control action, Input setting setup screen**

For a description of the setup procedure, see pages 11 and 12.

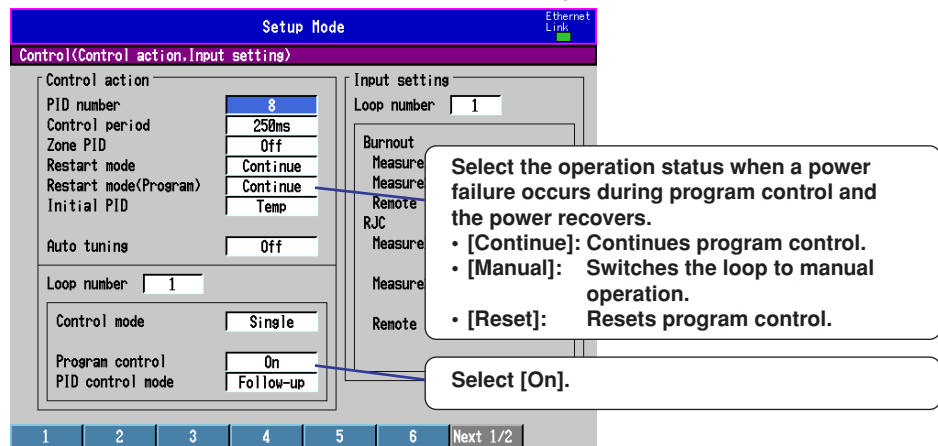

Program Control Related Setup Operations

Follow the flow chart below.

For further details on each function, see section 1.11, "Program Control Related Settings" in the *CX2000 User's Manual (IM 04L31A01-01E)* provided on the accompanying CD-ROM.

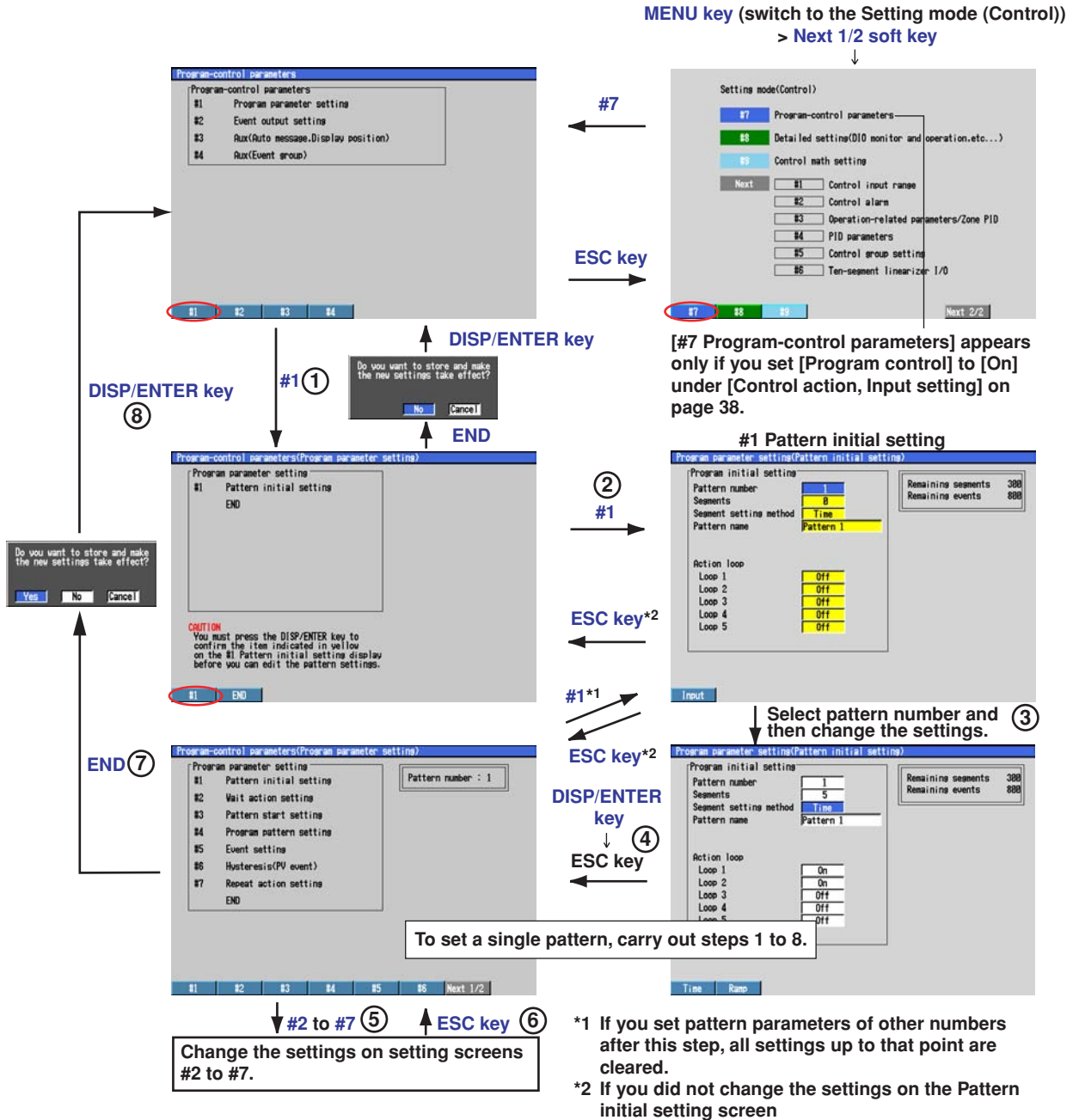

Setup Sequence

- First, enter pattern initial settings (1 to 4 above).
- Next, set [#2 Wait action setting] through [#7 Repeat action setting] (5 and 6 above).
- Return to the Program-control parameters screen (7 and 8 above).
- Set [#2 Event output setting] through [#4 Aux (Event group).]

Refer to the figure above for the following procedures.

Program Control Function (/PG1 and /PG2 Options)

Pattern Initial Setting

GROUP 1
Jan.08.2003 07:11:07 DISP 40hour

Program parameter setting(Pattern initial setting)

Program initial settings

Program number	1	Rema	Enter the program pattern number. /PG1: 1 to 4, /PG2: 1 to 30
Segments	7	Rema	Enter the number of segments to be used. 1 to 99
Segment setting method	Time		Select the time or ramp-rate (see below).
Pattern name	Pattern 1		Enter the pattern name (up to 16 characters).
Segment edit mode	Off		Specify the position of the segment to be deleted or added.

Input

Segment setting method: Time

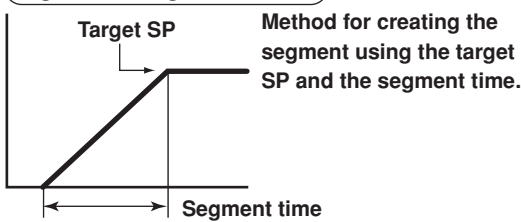

Segment setting method: Ramp-rate

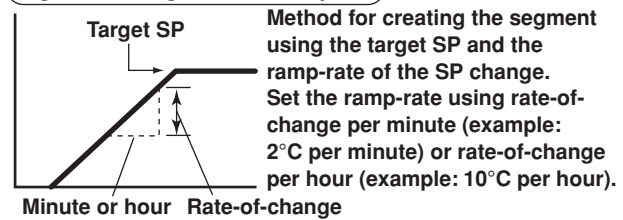

Wait Action Setting

Set 5 types of wait actions. Specify the wait action for each segment.

GROUP 1
Jan.08.2003 07:12:07 DISP 40hour

Program parameter setting(Wait action setting)

Wait action settings

Pattern number : 1

		1	2	3	4
Loop1	High	On	0.1	Off	Off
	Low		0.1		
Loop2	High	Off	Off	Off	Off
	Low				

Wait time 00:00:00

On Off

Wait zone number

Select [On] to set a wait zone.

Set the wait zone (engineering unit).

Wait zone High
SP
Wait zone Low

Enter the maximum wait time when using the wait function at the time of segment switching (see below).

Wait function at the time of segment switching

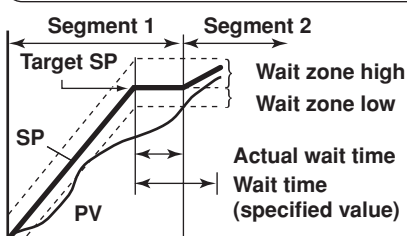

If the PV is outside the wait zone when the SP reaches the target SP of the segment, the program does not advance to the next segment. When the PV enters the wait zone, the program advances to the next segment. In addition, when the wait time elapses even if the PV does not enter the wait zone, the program advances to the next segment. If the wait zone is set to 00:00:00, the program does not advance to the next segment until the PV reaches the wait zone.

Wait function within the segment

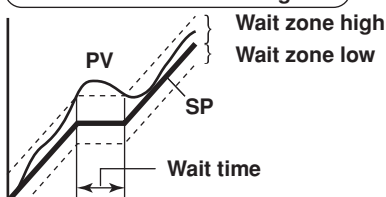

The advancing of the program control stops when the SP exits from the wait zone. When the PV returns within the wait zone, the advancing of the program control resumes. [Segment time] setting is irrelevant for wait within the segment. The advancing of the program control is stopped until the PV reaches the wait zone.

Pattern Start Setting

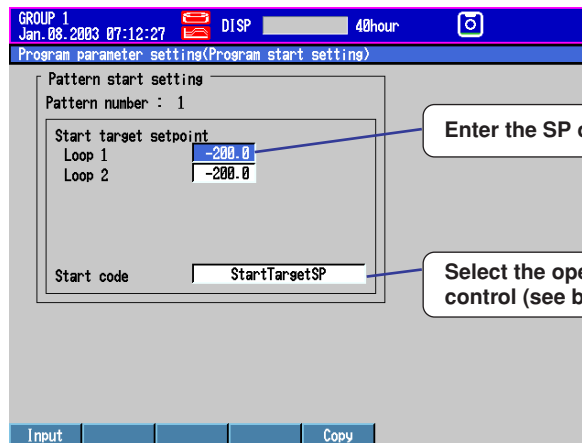

Select the operation start condition (Start code) from the following.

Start code: StartTargetSP

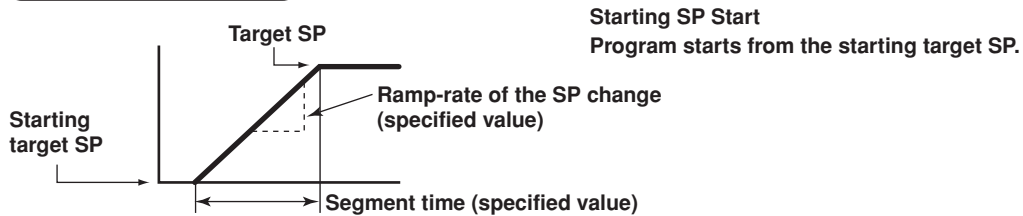

Start code: RampPV1Start to RampPV6Start

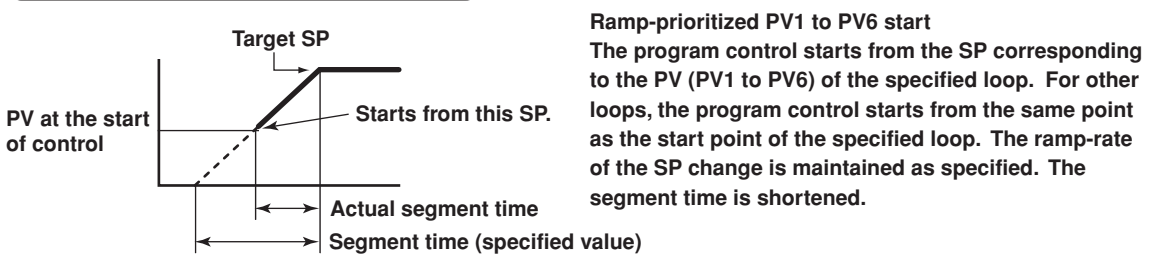

Start code: TimePVStart

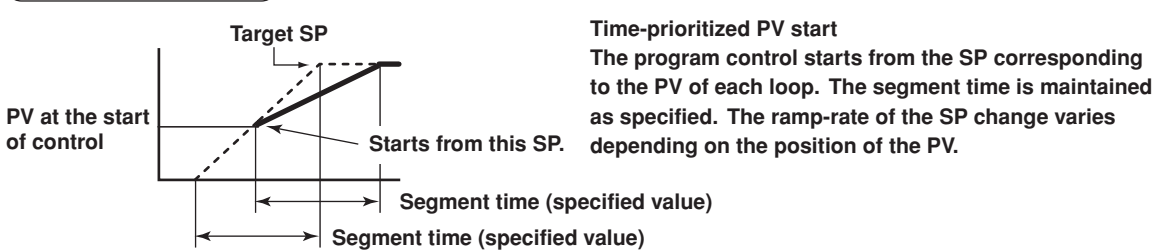

Program Pattern Setting

- When the segment setting method is set to [Time]

Select the segment number.

Select ramp or soak.

Enter the target SP of the segment.

Enter the segment time.

Select the PID number to be used (Not displayed when zone PID is selected).

Select the operation when ending the segment.

- [Continue]: Advance to the next segment.
- [Hold]: Hold the program progress.
- [Local]: End by setting the loop to local mode.
- [Reset]: End by stopping the loop.

Select the wait action type (see page 40).

Select the wait zone number to be applied.

- When the segment setting method is set to [Ramp]

Same as the figure above.

Select the ramp time unit.

[Hour]: 1 hour
[Minute]: 1 minute

Enter the rate-of-change per unit time using engineering unit.

Same as the figure above.

Event Setting

- When the event kind is set to [TimeEvent]

Select the segment number to which the event is to be assigned.

Select [TimeEvent] (see below).

Select the type of time event ([On/Off], [On/**], or [**/Off]) (see below).

Set the time for turning ON/OFF the contact output in terms of the time elapsed from the start point of the segment (see below).

Event No.	On-time	Off-time	Event Kind
1	On1 00:00:00	00:00:00	9 Off
2	On2 00:00:00		10 Off
3	On3	00:00:00	11 Off
4	Off		12 Off
5	Off		13 Off
6	Off		14 Off
7	Off		15 Off
8	Off		16 Off

Time event is a function used to turn ON or OFF the contact output after a specified time elapses by starting the clock from the time the segment operation is started.

TimeEvent Up to 16 time events can be specified for each segment. There are 3 types of time events.

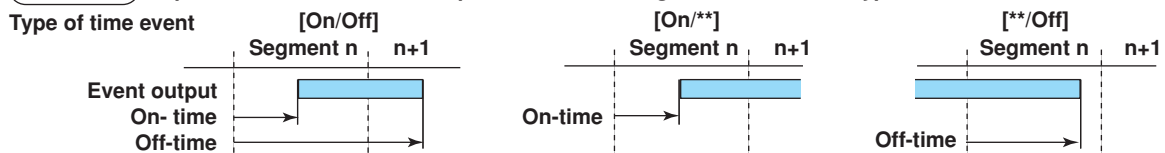

• When the event kind is set to [PVEvent]

GROUP 1
Jan. 08, 2003 07:13:46 DISP 40hour

Program parameter settings(Event settings)

Event setting
Pattern number : 1
Segment number : 1

Event kind : PVEvent

Loop	Type	Value	Loop
1	PV-High	1370.0	9 Off
2	Off		10 Off
3	Off		11 Off
4	Off		12 Off
5	Off		13 Off
6	Off		14 Off
7	Off		15 Off
8	Off		16 Off

Input ▲ ▼ Pattern

Select the segment number to which the event is to be assigned.

Select [PVEvent] (see below).

Select the loop to which the event is to be assigned.

Enter a value when the PV event is to be detected using engineering unit.

Select the type of PVEvent (see below).

This function outputs preset alarms such as PV alarms, SP alarms, and output alarms during program operation. Up to 16 PV events can be specified for each segment. PV events operate only within the specified segment.

PV event

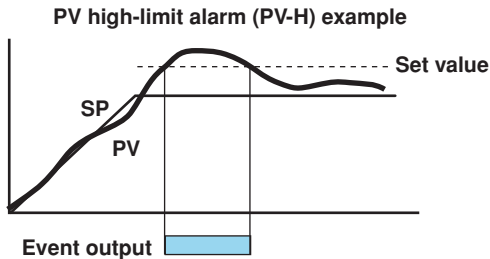

- Select the type of PV events from the following.
- PV-H (PV high-limit), PV-L (PV low-limit), Dev-H (deviation high-limit), Dev-L (deviation low-limit), Dev-H&L (deviation high & low limit), and D-W-H&L (deviation within high & low limits)
 - SP-H (SP high-limit) and SP-L (SP low-limit)
 - Out-H (output high-limit) and Out-L (output low-limit)

Event Output Destination Setting

The event output destination is set using the Event output setting display (see [Program-control parameters] display on page 39).

Repeat Action Setting

GROUP 1
Jan. 08, 2003 07:14:06 DISP 40hour

Program parameter settings(Repeat action setting)

Repeat settings
Pattern number : 1
Repeat action : On
Repeat frequency : 2
Repeat start segment : 3
Repeat end segment : 5

Off On Repeat

Select [On] or [Repeat] when using the repeat action.

- [On]: Repeats the specified number of times
- [Repeat]: Repeats infinitely

Enter the number of repetitions when [Repeat action] is set to [On].

Set the range of segments to be repeated.

Repeat action

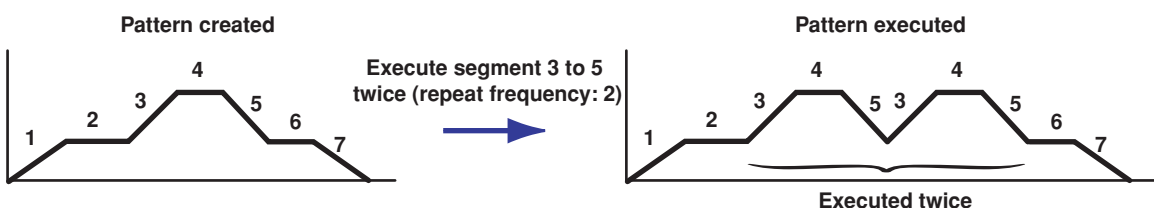

List of Parameters

Below is a list of parameters for the model with the various function options. However, settings related to the program control function option are not given.

Basic Setting Mode

#1 Alarm, A/D, Temperature

Parameter	Selectable Range or Selections	Initial Value
Alarm > Reflash	On/Off	Off
Alarm > Relay > AND	None, I01, I01-I02, I01-I03, ... , I01-I35, or I01-I36	None
Alarm > Action	Energize or Deenergize	Energize
Alarm > Behavior	Hold or Nonhold	Nonhold
Alarm > Indicator	Hold or Nonhold	Nonhold
Alarm > Rate of change > Increase/Decrease	1 to 15	1
Alarm > Hysteresis	On/Off	On
A/D Integrate > Integrate	Auto, 50 Hz, 60 Hz, or 100 ms	Auto
A/D > Scan interval	1 s or 2 s	1 s
A/D > First-CH	01 to 20 [†]	01
A/D > Last-CH	01 to 20 [†]	01
A/D > Burnout set	Off, Up, or Down	Off
A/D > RJC	Internal or External	Internal
A/D > Volt (uV)	-20000 μ V to 20000 μ V	0 μ V
Temperature > Unit	C or F	C

[†] 01 to 10 on models with 10 measurement channels.

#2 Memory, Memory and Trend, Memory Timeup

Parameter	Selectable Range or Selections	Initial Value
Memory > Save	Manual or Auto	Auto
Memory > Data	Display, E+D, or Event	Display
Memory > Event > Sample rate	1 s, 2 s, 5 s, 10 s, 30 s, 60 s, 120 s, 300 s, or 600 s	1 s
Memory > Event > Mode	Free, Trigger, or Repeat	Trigger
Memory > Event > Block	1, 2, 4, 8, or 16	1
Memory > Event > Data length	3 minutes to 31 days	1 h
Memory > Event > Pre-trigger	0, 5, 25, 50, 75, 95, or 100	0
Memory > Event > Trigger > Key	On/Off	On
Memory > Event > Trigger > External	On/Off	Off
Memory > Event > Trigger > Alarm	On/Off	Off
Memory and trend > Meas/Math/Loop CH	Meas CH, Math CH, Int CH, or Ext CH	Meas CH
Memory and trend > First-CH	Meas CH: 01 to 20 ¹ , Math CH: 31 to 60 ² , Int CH : 101 to 106 ³ , or Ext CH: 201 to 248	01
Memory and trend > Last-CH	Meas CH: 01 to 20 ¹ , Math CH: 31 to 60 ² , Int CH : 101 to 106 ³ , or Ext CH: 201 to 248	01
Memory and trend > On/Off	On/Off	On
Memory timeup > Timeup type	Off, Hour, Day, Week, or Month	Off
Memory timeup > Date	1 to 28	1
Memory timeup > Time (hour)	0 to 23	0

¹ 01 to 10 on models with 10 measurement channels.

² Can be specified only on models with the computation function option.

³ The maximum channel number depends on the maximum number of control loops.

#3 Keylock

Parameter	Selectable Range or Selections	Initial Value
Keylock > Use/Not	Use/Not	Not
Keylock > Password	Up to 6 alphanumeric characters	-
Keylock > Keys such as START	Free or Lock	Free
Key lock > Soft keys such as ALARM ACK	Free or Lock	Free
Key lock > Control settings such as the input range	Free or Lock	Free

#4 Key login

Parameter	Selectable Range or Selections	Initial Value
Key login > Use/Not	Use/Not	Not
Key login > Auto logout	On/Off	Off
Key login > UserID Use/Not	Use/Not	Not
Key login > Number	1, 2, 3, 4, 5, 6, or 7	1
Key login > On/Off	On/Off	On
Key login > User name	Up to 16 alphanumeric characters	user1
Key login > User ID	Up to 4 alphanumeric characters	1
Key login > Password	Up to 6 alphanumeric characters	–
Key login > setup	On or Off	On

#5 Load, Initialize...

Parameter	Selectable Range or Selections	Initial Value
Load, Initialize > #1 Load settings	–	–
Load, Initialize > #2 Delete	–	–
Load, Initialize > #3 Format	–	–
Load, Initialize > #4 Initialize > Kind	Clear1 to Clear3	Clear3

#6 Option

Parameter	Selectable Range or Selections	Initial Value
Remote > Action No. 1 to No. 8	None, MemoryStartStop, Trigger, AlarmACK, TimeAdjust, MathStartStop, MathReset, Manual sample, Panel1Load, Panel2Load, Panel3Load, Message1, Message2, Message3, Message4, Message5, Message6, Message7, Message8, Snapshot	None
Timer(TLOG) > No.1 > Mode	Off, Relative, or Absolute	Absolute
Timer(TLOG) > No.1 > Interval	1 min, 2 min, 3 min, 4 min, 5 min, 6 min, 10 min, 12 min, 15 min, 20 min, 30 min, 1 h, 2 h, 3 h, 4 h, 6 h, 8 h, 12 h, or 24 h	1 h
Timer(TLOG) > No.1 > Ref.time	0:00 to 23:00	0:00
Timer(TLOG) > No.1 > Reset	On/Off	Off
Timer(TLOG) > No.1 > Action	Off or DataSave	Off
Timer(TLOG) > No.2, No.3 > Mode	Off, Relative, or Absolute	Off
Report > Report set	Off, Hour, Day, Hour+Day, Day+Week, or Day+Month	Off
Report > Date ¹	1 to 28	1
Report > Day of the week ²	SUN, MON, TUE, WED, THU, FRI, or SAT	SUN
Report > Time(hour)	0:00 to 23:00	0:00
Report > Report CH	R01 to R30	R01
Report > Off/On	On/Off	On
Report > Channel	01 to 60	01
Report > Sum scale	Off, /s, /min, /h, or /day	/s

¹ When the report type is monthly report² When the report type is weekly report

List of Parameters

#7 Communication

<#1 Ethernet, Serial>

Parameter	Selectable Range or Selections	Initial Value
Ethernet > IP-address	–	0.0.0.0
Ethernet > Subnet mask	–	0.0.0.0
Ethernet > Default gateway	–	0.0.0.0
Ethernet > DNS On/Off	On/Off	Off
Ethernet > Server search order > Primary	–	0.0.0.0
Ethernet > Server search order > Secondary	–	0.0.0.0
Ethernet > Host name	Up to 64 alphanumeric characters	–
Ethernet > Domain name	Up to 64 alphanumeric characters	–
Ethernet > Domain suffix search order > Primary	Up to 64 alphanumeric characters	–
Ethernet > Domain suffix search order > Secondary	Up to 64 alphanumeric characters	–
Serial > Baud rate	1200, 2400, 4800, 9600, 19200, or 38400 bps	9600 bps
Serial > Data length	7 or 8	8 bit
Serial > Parity	Odd, Even, and None	Even
Serial > RS-232 > Handshaking	Off:Off, XON:XON, XON:RS, or CS:RS	Off:Off
Serial > RS-422/485 > Address	1 to 32	1
Serial > RS-422/485 > Protocol	Normal, Modbus, Modbus-M, or Ladder*	Normal
Memory output	Ethernet or serial	Ethernet

* Ladder is only on models with the ladder communication option

<#2 FTP client>

Parameter	Selectable Range or Selections	Initial Value
FTP transfer file > Disp&Event data	On/Off	Off
FTP transfer file > Report	On/Off	Off
FTP connection	Primary or Secondary	Primary
FTP connection > FTP server name	Up to 64 alphanumeric characters	–
FTP connection > Port number	1 to 65535	21
FTP connection > Login name	Up to 32 alphanumeric characters	–
FTP connection > Password	Up to 32 alphanumeric characters	–
FTP connection > Account	Up to 32 alphanumeric characters	–
FTP connection > PASV mode	On/Off	Off
FTP connection > Initial path	Up to 64 alphanumeric characters	–

<#3 Control (Login, Timeout)>

Parameter	Selectable Range or Selections	Initial Value
Ethernet login > Use/Not	Use/Not	Not
Ethernet login > Level	admin, user1, user2, user3, user4, user5, or user6	admin
Ethernet login > Level > On/Off	On/Off	On
Ethernet login > Level > User name	Up to 16 alphanumeric characters	admin
Ethernet login > Level > Password	Up to 6 alphanumeric characters	0
Application time out > On/Off	On/Off	Off
Application time out > Time	1 to 120	1 min
Keep alive > On/Off	On/Off	On

<#4 Modbus master>

Parameter	Selectable Range or Selections	Initial Value
Basic settings > Read cycle	125 ms, 250 ms, 500 ms, 1 s, 2 s, 5 s, 10 s, 15 s, 20s, or 30s	2 s
Basic settings > Timeout	125 ms, 250 ms, 500 ms, 1 s, 2 s, 5 s, 10 s, or 1 min	2 s
Basic settings > Retrials	Off, 1, 2, 3, 4, 5, 10, or 20	1
Command settings > 1 to 8	On/Off	Off
Command settings > 1 to 8 > Comm. Data First	C01 to C30	C01
Command settings > 1 to 8 > Comm. Data Last	C01 to C30	C01
Command settings > 1 to 8 > Address	1 to 247	1
Command settings > 1 to 8 > Salve Registers	Input registers: 30001 to 39999, 300001 to 365535 Hold registers: 40001 to 49999, 400001 to 465535	30001
Command settings > 1 to 8 > Type	INT16, UINT16, INT32_B, INT32_L, UINT32_B, INT32_L, FLOAT_B, or FLOAT_L	INT16

<#5 AUX>

Parameter	Selectable Range or Selections	Initial Value
Recovery Status for Comm. Buffer > DO/SW	Continue, Clear	Clear
Modbus master/Ext loop > Auto recovery	On/Off	Off

#8 Web, E-Mail

<#1 Web>

Parameter	Selectable Range or Selections	Initial Value
Web > Use/Not	Use/Not	Not
Web > Page type	Operator or Monitor	Operator
Web > On/Off	On/Off	Off
Web > Command	On/Off	Off
Web > Access control	On/Off	Off
Web > User name	Up to 16 alphanumeric characters	–
Web > Password	Up to 6 alphanumeric characters	–

<#2 Basic E-Mail Settings>

Parameter	Selectable Range or Selections	Initial Value
Basic E-Mail settings > SMTP server name	Up to 64 alphanumeric characters	–
Basic E-Mail settings > Port number	0 to 65535	25
Basic E-Mail settings > Recipient 1	Up to 150 alphanumeric characters	–
Basic E-Mail settings > Recipient 2	Up to 150 alphanumeric characters	–
Basic E-Mail settings > Sender	E-mail address assigned by the network administrator (up to 64 alphanumeric characters)	–

<#3 Alarm E-Mail Settings>

Parameter	Selectable Range or Selections	Initial Value
Alarm E-Mail settings > Recipient1	On/Off	Off
Alarm E-Mail settings > Recipient2	On/Off	Off
Alarm E-Mail settings > Alarm1 to 4	On/Off	Off
Alarm E-Mail settings > Include INST	On/Off	Off
Alarm E-Mail settings > Include source URL	On/Off	Off
Alarm E-Mail settings > Subject	Up to 32 alphanumeric characters	(CX) Alarm_summary
Alarm E-Mail settings > Header1	Up to 64 alphanumeric characters	–
Alarm E-Mail settings > Header2	Up to 64 alphanumeric characters	–

<#4 Scheduled E-Mail Settings>

Parameter	Selectable Range or Selections	Initial Value
Scheduled E-Mail settings > Recipient1	On/Off	Off
Scheduled E-Mail settings > Interval	1 h, 2 h, 3 h, 4 h, 6 h, 8 h, 12 h, or 24 h	24 h
Scheduled E-Mail settings > Ref.time	00:00 to 23:59	00:00
Scheduled E-Mail settings > Recipient2	On/Off	Off
Scheduled E-Mail settings > Interval	1 h, 2 h, 3 h, 4 h, 6 h, 8 h, 12 h, or 24 h	24 h
Scheduled E-Mail settings > Ref.time	00:00 to 23:59	00:00
Scheduled E-Mail settings > Include INST	On/Off	Off
Scheduled E-Mail settings > Include source URL	On/Off	Off
Scheduled E-Mail settings > Subject	Up to 32 alphanumeric characters	(CX) Periodic_data
Scheduled E-Mail settings > Header1	Up to 64 alphanumeric characters	–
Scheduled E-Mail settings > Header2	Up to 64 alphanumeric characters	–

<#5 System E-Mail Settings>

Parameter	Selectable Range or Selections	Initial Value
System E-Mail settings > Recipient1	On/Off	Off
System E-Mail settings > Recipient2	On/Off	Off
System E-Mail settings > Include source URL	On/Off	Off
System E-Mail settings > Subject	Up to 32 alphanumeric characters	(CX) System_warning
System E-Mail settings > Header1	Up to 64 alphanumeric characters	–
System E-Mail settings > Header2	Up to 64 alphanumeric characters	–

List of Parameters

<#6 Report E-Mail Settings>

Parameter	Selectable Range or Selections	Initial Value
Report E-Mail settings > Recipient1	On/Off	Off
Report E-Mail settings > Recipient2	On/Off	Off
Report E-Mail settings > Include source URL	On/Off	Off
Report E-Mail settings > Subject	Up to 32 alphanumeric characters	(CX) Report_data
Report E-Mail settings > Header1	Up to 64 alphanumeric characters	–
Report E-Mail settings > Header2	Up to 64 alphanumeric characters	–

#9 Aux, Time zone

Parameter	Selectable Range or Selections	Initial Value
AUX > Tag/Channel	Tag/Channel	Tag
AUX > Memory alarm	Off, 1 h, 2 h, 5 h, 10 h, 20 h, 50 h, or 100 h	1 h
AUX > Language	English, Japanese, German, French, or Chinese	English
AUX > Partial	Use/Not	Not
Time zone > Difference from GMT	–1200 to 1200	0
Batch	Use/Not	Use

#10 Control

<#1 Control action, Input setting>

Parameter	Selectable Range or Selections	Initial Value
Control action > PID number	1 to 8	8
Control action > Control period	250 ms, 500 ms, or 1 s [*]	250 ms
Control action > Zone PID	On/Off	Off
Control action > Restart mode	Continue, Manual, or Auto	Continue
Control action > Restart mode (Program)	Continue, Manual, or Reset	Continue
Control action > Initial PID	Temp or Press+Flow	Temp
Control action > 6/4loop select	6 loop or 4 loop	6 loop
Control action > Auto tuning	On/Off	Off
Control action > Loop number	1 to 6	1
Control action > Control mode	Off, Single, Cascade, PVSwitching, or Retrans	Single
Control action > Control mode > Method	Range, PVHigh, or Signal	Range
Control action > Program control	On/Off	Off
Control action > PID control mode	Follow-up or Fixed-point	Follow-up
Input setting > Loop number	1 to 6	1
Input setting > Burnout > Measure1	Off, Up, or Down	Up
Input setting > Burnout > Measure2	Off, Up, or Down	Up
Input setting > Burnout > Remote	Off, Up, or Down	Up
Input setting > RJC > Measure1	External, Internal	Internal
Input setting > RJC > Measure1 > Volt (μV)	–20000 μV to 20000 μV	0 μV
Input setting > RJC > Measure2	External, Internal	Internal
Input setting > RJC > Measure2 > Volt (μV)	–20000 μV to 20000 μV	0 μV
Input setting > RJC > Remote	External, Internal	Internal
Input setting > RJC > Remote > Volt (μV)	–20000 μV to 20000 μV	0 μV

^{*} Fixed to 1 s for A/D integral time of 100 ms.

<#2 DI/DO/SW-registration/AUX (Alarm mode...)>

Parameter	Selectable Range or Selections	Initial Value
Contact input > Module	CTRL1-DI, CTRL2-DI, CTRL3-DI, EXT1-RI, CTRL1-DO, CTRL2-DO, CTRL3-DO, EXT1-RO, INT-SW1, INT-SW2, INT-SW3	CTRL1-DI
Contact input > DI001 to 006	None, AllControlStop,	None
Contact input > DI101 to 106	AllControlStart, ControlStart/Stop (1 to 6), Remote/Local (1 to 6), Auto/Man (1 to 6), Cascade (1-2 or 3-4), Auto1-2 or 3-4,	
Contact input > RI001 to 012	Man1-2 or 3-4, SPNumber0 to 3 bit, ProgramRun,	
Contact input > DO001 to 006	ProgramReset, Hold, Advance, PatternNo0 to 4bit,	
Contact input > DO101 to 106	PVSwitching1 to 4, MemoryStart/Stop,	
Contact input > RO001 to 012	Trigger, AlarmAck, TimeAdjust,	
Contact input > SW001 to 036	MathStart/Stop, MathReset, ManualSample, Panel1Load to Panel3Load, Message1 to 8, Snapshot	

Parameter	Selectable Range or Selections	Initial Value
AUX > Loop number	1 to 6	1
AUX > Remote setting	Off or Remote	Off
AUX > Alarm mode	ALWAYS, STOP, or STOP/MAN	ALWAYS
AUX > SP No. selection source 1 to 6	On/Off	1: On, 2-6: Off
AUX > PV/SP math	On/Off	Off
AUX > CLOG error	Error, Skip	Error
AUX > Event output setting	Common/Separate	Common

<#3 Output processing>

Parameter	Selectable Range or Selections	Initial Value
Output processing > Loop number	1 to 6	1
Output processing > Control output	Relay, Voltage-pulse, Current-output, or On/Off-control	Current-output
Output processing > Cycle time	1 s to 1000 s	30 s
Output processing > Analog-output type	4-20 mA, 0-20 mA, 20-4 mA, or 20-0 mA	4-20 mA

<#4 Relay>

Parameter	Selectable Range or Selections	Initial Value
Relay > Module	CTRL1-2, CTRL3-4, CTRL5-6, or EXTUDIO	CTRL1-2
Relay > FAIL	On/Off	Off
Relay > Self diagnosis	On/Off	Off
Relay > DO001 to 006	De_energize/Hold, De_energize/Nonhold, Energize/Hold, or Energize/Nonhold	Energize/Nonhold
Relay > RO001 to 012	De_energize/hold, De_energize/Nonhold, Energize/Hold, or Energize/Nonhold	Energize/Nonhold

<#5 Tuning setting>

Parameter	Selectable Range or Selections	Initial Value
Tuning setting > Loop number	1 to 6	1
Tuning setting > 01 to 21	On/Off	01-12: On, 13-21: Off
Tuning setting > 01 to 21 > Item ID	SP, A1, A2, A3, A4, P, I, D, OH, OL, MR, PO, H, DR, BS1, FL1, BS2, FL2, RT, RBS, RFL, or W01 to W36	01: SP, 02: A1, 03: A2, 04: A3, 05: A4, 06: P, 07: I, 08: D, 09: OH, 10: OL, 11: MR, 12: PO, 13 - 21: SP
Tuning setting > 01 to 21 > Item name	Up to 6 alphanumeric characters	01-12: same as Item ID, 13 - 21: -

<#6 External loop setting>

Parameter	Value or Selections	Initial Value
#1 Basic setting		
Loop number	Ext1 to Ext16	Ext1
Comm. Off/On	On/Off	Off
Modbus address	1 to 247	1
Connecting model	UT320, UT321, UT350, UT351, UT420, UT450, UT520, UT550, UT750, or Others	UT320
Loop select	First or Second	First
Tag	Up to 8 alphanumeric characters	EXT-01
Tag comment	Up to 8 alphanumeric characters	-
Auto reading	Execute	Execute
PV > Decimals	0 to 4	0
PV > Unit	Up to 6 alphanumeric characters	-
SP > Decimals	0 to 4	0
SP > Unit	Up to 6 alphanumeric characters	-
OUT > Decimals	0 to 4	0
OUT > Unit	Up to 6 alphanumeric characters	%
Control span lower	-30000 to 30000, span width: 30000	0
Control span upper	-30000 to 30000, span width: 30000	10

List of Parameters

Parameter	Value or Selections	Initial Value
Control mode	SingleLoopControl, CascadePrimaryLoop, CascadeSecondaryLoop, CascadeControl, ControlBackup, PVSwitching, PVAutoSelector, PVHoldFunction, DualLoopControl, Temperature-Humidity, Cascade-2Uni, PVSwitching-2Uni, or PVAutoSelector-2Uni	SingleLoopControl
Control output	Relay, Voltage-pulse, Current-output, or On/Off-control	Relay
Alarm	Off, PH-H-E (PV high-limit alarm (energize)), PV-L-E (PV low-limit alarm (energize)), Dev-H-E (Deviation high-limit alarm (energize)), Dev-L-E (Deviation low-limit alarm (energize)), Dev-H-D (Deviation high-limit alarm (deenergize)), Dev-L-D (Deviation low-limit alarm (deenergize)), Dev-HL-E (Deviation high & low limit alarm (energize)), D-W-HL-E (Deviation within high & low limits alarm (energize)), PV-H-D (PV high-limit alarm (deenergize)), PV-L-D (PV low-limit alarm (deenergize)), PV-H-ES (PV high-limit alarm (energize/hold)), PV-L-ES (PV low-limit alarm (energize/hold)), Dev-H-ES (Deviation high-limit alarm (energize/hold)), Dev-L-ES (Deviation low-limit alarm (energize/hold)), Dev-H-DS (Deviation high-limit alarm (deenergize/hold)), Dev-L-DS (Deviation low-limit alarm (deenergize/hold)), Dev-HL-ES (Deviation high & low limit alarm (energize/hold)), D-W-HL-ES (Deviation within high & low limits alarm (energize/hold)), PV-H-DS (PV high-limit alarm (deenergize/hold)), PV-L-DS (PV low-limit alarm (deenergize/hold)), TimeUp1 (Timer, upward detection, hours & minutes), TimeDown1 (Timer, downward detection, hours & minutes), TimeUp2 (Timer, upward detection, minutes & seconds), TimeDown2 (Timer, downward detection, minutes & seconds), Sensor (Sensor grounding alarm), Prog-Diag (Self diagnosis output), FAIL (FAIL output), SP-H (SP high-limit), SP-L (SP low-limit), Out-H (Output high-limit), Out-L (Output low-limit), Burnout1 (Heater burnout alarm 1), or Burnout2 (Heater burnout alarm 2),	Off
#2 Parameter address setting		
Loop number	Ext1 to Ext16	Ext1
PV: Input	30001 to 39999, 300001 to 365535, 40001 to 49999, or 400001 to 465535	40003
SP : Setting	30001 to 39999, 300001 to 365535, 40001 to 49999, or 400001 to 465535	40004
OUT: Output	30001 to 39999, 300001 to 365535, 40001 to 49999, or 400001 to 465535	40005
Control mode	30001 to 39999, 300001 to 365535, 40001 to 49999, or 400001 to 465535	40008
Remote/Local	30001 to 39999, 300001 to 365535, 40001 to 49999, or 400001 to 465535	40008
Operation STOP/RUN	30001 to 39999, 300001 to 365535, 40001 to 49999, or 400001 to 465535	40205
Alarm status	30001 to 39999, 300001 to 365535, 40001 to 49999, or 400001 to 465535	40011
SP number	30001 to 39999, 300001 to 365535, 40001 to 49999, or 400001 to 465535	40010
PID number	30001 to 39999, 300001 to 365535, 40001 to 49999, or 400001 to 465535	40009
Auto reading	30001 to 39999, 300001 to 365535, 40001 to 49999, or 400001 to 465535	40008

Parameter	Value or Selections	Initial Value
#3 Tuning setting		
Tuning setting > Loop number	Ext1 to Ext16	Ext1
Tuning setting > 01 to 21	On/Off	Off
Tuning setting > Item ID	SP, A1, A2, A3, A4, P, I, D, OH, OL, MR, H, DR, DB, PO, or ETC	ETC
Tuning setting > Item name	Up to 6 alphanumeric characters	ETC
Tuning setting > Register address	30001 to 39999, 300001 to 365535, 40001 to 49999, 400001 to 465535	40001
Tuning setting > Decimal point	0 to 4	0
Tuning setting > Range lower	-30000 to 30000, span width: 30000	0
Tuning setting > Range upper	-30000 to 30000, span width: 30000	10

Setting mode (Control)

#1 Control input range

Parameter	Selectable Range or Selections	Initial Value
Input range > Loop number	1 to 6	1
Input range > Input type	PV1, PV2, RemoteSP, or PVrange	PV1
Input range > Mode	TC, RTD, Scale, or 1-5V	TC
Input range > Type	DCV, TC, or RTD	TC
Input range > Range	TC: R/S/B/K/E/J/T/N/W/L/U/PLATI/PR/WRe RTD: PT/JPT DCV: 20mV, 60mV, 200mV, 2V, 6V, 20V, or 50V	K PT 6 V
Input range > Span lower-limit	Within the range of Range	-200.0
Input range > Span upper-limit	Within the range of Range	1370.0
Input range > PV range	-30000 to 30000	Lower: 0.0, Upper: 2000.0
Input range > PV switching Lower limit	-30000 to 30000	0.0
Input range > PV switching Upper limit	-30000 to 30000	2000.0
Input range > Scale	-30000 to 30000	Lower: 0.00, Upper: 200.00
Input range > Unit	Up to 6 alphanumeric characters	-
Input range > Square root	On/Off	Off
Input range > Low-cut	0.0% to 5.0%	1.0%
Input range > Bias	On/Off Selectable range when On: EUS (-100.0% to 100.0%) of the measurement span	Off 0.0%
Input range > Filter	On/Off 1 s to 120 s	Off 1 s
Input range > Ratio	On/Off Selectable range when On: 0.001 to 9.999	Off 1.000

#2 Control alarm

Parameter	Selectable Range or Selections	Initial Value
Alarm > Loop number	1 to 6	1
Alarm > 1 to 4	On/Off	Off
Alarm > Type	PV-H (PV high-limit), PV-L (PV low-limit), Dev-H (deviation high-limit), Dev-L (deviation low-limit), Dev-H&L (deviation high & low limit), D-W-H&L (deviation within high & low limits), SP-H (SP high-limit), SP-L (SP low-limit), Out-H (Output high-limit), or Out-L (Output low-limit)	PV-High
Alarm > Standby	On/Off	Off
Alarm > Relay output	On/Off	Off
Alarm > Number	DO001 to DO006, DO101 to DO106, DO201 to DO206, RO001 to RO012, or SW001 to SW036	DO001, DO101, DO201
Alarm > SP number	1 to 8	1
Alarm > Alarm value1 to 4	PV high/low limits: EU (0 to 100%) of measurement span, SP high/low limits: EU (0 to 100%) of measurement span, Deviation high/low limits: EUS (-100 to 100%) of measurement span, Deviation high & low limit and deviation within high & low limits: EUS (0 to 100%) of measurement span, or Output high/low limit: -5.0 to 105.0%	1370.0

List of Parameters

#3 Operation-related parameter/zone PID

Parameter	Selectable Range or Selections	Initial Value
Operation related/zone PID > Loop number	1 to 6	1
Operation related/zone PID > Suppressing function	Off or Overshoot	Off
Operation related/zone PID > Ramp-rate time unit	Hour, Minute, or Second	Hour
Operation related/zone PID > SP ramp-down-rate	On/Off Selectable range when On: 1digit to EUS (100.0%) of the measurement span	Off 1570.0
Operation related/zone PID > SP ramp-up-rate	On/Off Selectable range when On: 1digit to EUS (100.0%) of the measurement span	Off 1570.0
Operation related/zone PID > Tag	Up to 8 alphanumeric characters	INT-01
Operation related/zone PID > Tag comment	Up to 8 alphanumeric characters	–
Operation related/zone PID > Reference point	EU (0.0 to 100.0%) of the measurement span	1370.0
Operation related/zone PID > Switching hysteresis	EU (0.0 to 100.0%) of the measurement span	7.8
Operation related/zone PID > Reference deviation	On/Off Selectable range when On: 1digit to EUS (100.0%) of the measurement span	Off 7.8

#4 PID parameters

Parameter	Selectable Range or Selections	Initial Value
PID parameters > Loop number	1 to 6	1
PID parameters > PID Number	1 to 8	1
PID parameters > Target setpoint	EU (0% to 100%) of the measurement span	–200.0
PID parameters > Proportional band(P)	0.1% to 999.9%	5.0%
PID parameters > Integral time(I)	0 s to 6000 s	240 s
PID parameters > Derivative time(D)	0 s to 6000 s	60 s
PID parameters > Output lower limit	–5.0% to 105.0%	0.0%
PID parameters > Output upper limit	–5.0% to 105.0%	100.0%
PID parameters > Shutdown	On/Off	Off
PID parameters > Manual reset	–5.0% to 105.0%	50.0%
PID parameters > Relay hysteresis > Value	EUS (0.0 to 100.0%) of the measurement span	7.8
PID parameters > Relay hysteresis > Position	Mid, High, or Low	Mid
PID parameters > Reverse/Direct	Reverse or Direct	Reverse
PID parameters > Preset output	–5.0% to 105.0%	0.0%

#5 Control group setting

Parameter	Selectable Range or Selections	Initial Value
Control group > Group number	1 to 8	1
Control group > Group name	Up to 16 alphanumeric characters	CONTROL GROUP1
Control group > 1 to 6	On/Off	On
Control group > 1 to 6 > Kind	Int-Loop, Ext-Loop, or Meas-CH	Int-Loop
Control group > 1 to 6 > Number	Int-Loop: 01 to 06 Ext-Loop: 01 to 16 Meas-CH: 01 to 20	1: 01, 2: 02, 3: 03, 4: 04, 5: 05, 6: 06

#6 Ten-segment linearizer I/O

Parameter	Selectable Range or Selections	Initial Value
Ten-segment linearizer I/O > Loop number	1 to 6	1
Ten-segment linearizer I/O > Input type	PV1 or PV2	PV1
Ten-segment linearizer I/O > Mode	Off, Biasing, or Approximation	Off
Ten-segment linearizer I/O > Input 1 to 11	Linearizer bias: EU (–5.0% to 105.0%) of the measurement span Linearizer approximation: EU (–5.0% to 105.0%) of the measurement span	1: –200.0, 2: 1370.0, 3 to 11: –200.0
Ten-segment linearizer I/O > Output 1 to 11	Linearizer bias: EUS (–100.0% to 100.0%) of the measurement span Linearizer approximation: EU (–5.0% to 105.0%) of the measurement span	0.0

#7 Program control related (only when program control is ON)**<#1 Program parameter setting>**

Parameter	Selectable Range or Selections	Initial Value
#1 Pattern initial setting		
Program initial setting > Pattern number	1 to 4 (/PG1), 1 to 30 (/PG2)	1
Program initial setting > Segments	0 to 99	0
Program initial setting > Segment setting method	Time, Ramp	Time
Program initial setting > Pattern name	Up to 16 alphanumeric characters	Pattern 1
Program initial setting > Action loop > Loop 1 to 6	On/Off	Off
#2 Wait action setting		
Wait action setting > Wait zone 1 to 5 > Loop 1 to 6 > High, Low	On/Off EUS (100.0%) of the measurement span	Off 1 digit
Wait action setting > Wait time	00:00:00 to 99:59:59	00:00:00
#3 Pattern start setting		
Pattern start setting > Start target setpoint > Loop 1 to 6	EU (0% to 100%) of the measurement span	-200.0
Pattern start setting > Start code	StartTargetSP, RampPV1 to RampPV6, TimePV,	StartTargetSP
#4 Program pattern setting		
Program pattern setting > Segment number	1 to specified number of segments	1
Program pattern setting > Ramp/Soak select	Ramp, Soak	Ramp
Program pattern setting > Target setpoint > Loop 1 to 6	EU (0% to 100%) of the measurement span	-200.0
Program pattern setting > Segment time ¹	00:00:00 to 99:59:59	00:00:01
Program pattern setting > Ramp-rate time unit ²	Hour, Minute	Hour
Program pattern setting > Ramp ²	1 digit to EUS (100.0%) of the measurement span	1 digit
Program pattern setting > Segment PID group No.	1 to specified PID number	1
Program pattern setting > Segment shift action	Continue, HoldShift, LocalShift, ResetShift	Continue
Program pattern setting > Wait action	Off, Shift, Within	Off
Program pattern setting > Wait zone number	1 to 5	1
#5 Event setting		
Event setting > Segment number	1 to specified number of segments	1
Event setting > Event kind	PVEvent, TimeEvent	TimeEvent
Event setting > TimeEvent 1 to 16	On1, On2, On3, Off	Off
Event setting > TimeEvent 1 to 16 > On-time, Off-time	00:00:00 to 99:59:59	00:00:00
Event setting > PVEvent 1 to 16 > Loop	Off, 1 to 6	Off
Event setting > PVEvent 1 to 16 > Loop > Type	PV-High, PV-Low, Deviation-High, Deviation-Low, Deviation-H&L, Dev-within-H&L, SP-High, SP-Low, Output-High, Output-Low	PV-High
Event setting > PVEvent 1 to 16 > Loop > Value	PV: EU (0% to 100%) of the measurement span Deviation: EUS (0% to 100%) of the measurement span SP: EU (0% to 100%) of the measurement span Output: -5.0 % to 105.0 %	1370.0 1570.0 1370.0 105.0 %
#6 Hysteresis (PV event)		
Hysteresis (PV event) > PV event > Hysteresis 1 to 16	0.0% to 10.0	0.5%
#7 Repeat action setting		
Repeat action setting > Repeat action	Off, On, Repeat	Off
Repeat action setting > On > Repeat frequency	1 to 999	1
Repeat action setting > Repeat action > Repeat start segment	1 to specified number of segments	1
Repeat action setting > Repeat action > Repeat end segment	1 to specified number of segments	1

¹ When [Time] is specified for the segment setting method.

² When [Ramp] is specified for the segment setting method.

<#2 Event output setting*>

Parameter	Selectable Range or Selections	Initial Value
Event output > Pattern number	1 to 4 (/PG1), 1 to 30 (/PG2)	1
Event output > Event kind	PVEvent, TimeEvent	TimeEvent
Event output > Relay Output EV1 to 16	On, Off	Off
Event output > On EV1 to 16 > Number	DO001 to DO006, DO101 to DO106, DO201 to DO206, RO001 to RO012, SW001 to SW036	DO001
Program pattern end signal > Relay Output	On, Off	Off
Program pattern end signal > On > Number	DO001 to DO006, DO101 to DO106, DO201 to DO206, RO001 to RO012, SW001 to SW036	DO001

* With version 3.01, event output setting is included as item #6 within #1 Program pattern setting.

List of Parameters

<#3 AUX (Auto message, Display position)>

Parameter	Selectable Range or Selections	Initial Value
AUX (Auto message, Display position) > Auto message for program Run/Reset On/Off	On, Off	On
AUX (Auto message, Display position) > Program display position > Position > Loop 1 to 6	1 to 6	Loop 1 to 6: 1 to 6
AUX (Auto message, Display position) > Auto change to program run display	On, Off	Off

<#4 AUX (Event group)>

Parameter	Selectable Range or Selections	Initial Value
AUX (Event group) > Pattern number	1 to 4 (/PG1) or 1 to 30 (/PG2)	1
AUX (Event group) > 1 to 5	On, Off	On
AUX (Event group) > On 1 to 5 > Kind	PVEvent, TimeEvent	Time Event
AUX (Event group) > Number	01 to 05	1 to 5: 01 to 05

#8 Detailed settings (#7 when the program control function is OFF)

<#1 Control function>

Parameter	Selectable Range or Selections	Initial Value
Control function > Loop number	1 to 6	1
Control function > SP Tracking	Off/On	On
Control function > PV tracking	On/Off	Off
Control function > Target setpoint limiter > Lower	EU (0.0% to 100.0%) of the measurement span	-200.0
Control function > Target setpoint limiter > Upper	EU (0.0% to 100.0%) of the measurement span	1370.0
Control function > Output velocity limiter	On/Off	Off
	Enter the value for On: 0.1%/s to 100.0%/s	100.0%/s
Control function > Anti-reset windup	Auto or Manual	Auto
	Enter the value for Manual: 50.0% to 200.0%	100.0%

<#2 Hysteresis (Alarm)>

Parameter	Selectable Range or Selections	Initial Value
Hysteresis (Alarm, PV event) > Alarm > Loop number	1 to 6	1
Hysteresis (Alarm, PV event) > Alarm > Hysteresis1 to 4	EUS (0.0% to 10.0%) of the measurement span	7.8

<#3 DIO monitor and operation setting>

Parameter	Selectable Range or Selections	Initial Value
DIO monitor and operation setting > DIO entry number	01 to 36	01
DIO monitor and operation setting > On/Off	On, Off	Off
DIO monitor and operation setting > Kind	DI-1, DO-1, DO-2, DIO-11, DIO12, DO-2P, DIO-12P	DI-1
DIO monitor and operation setting > SW number	SW001 to SW036	SW001
DIO monitor and operation setting > DO number > ON	DO001 to DO006, DO101 to DO106, DO201 to DO206, RO001 to RO012,	DO001
DIO monitor and operation setting > DO number > OFF	DO001 to DO006, DO101 to DO106, DO201 to DO206, RO001 to RO012,	DO001
DIO monitor and operation setting > DI number	DI001 to DI006, DI101 to DI106, DI201 to DI206, RI001 to RI012,	DI001
DIO monitor and operation setting > Tag	Up to 8 alphanumeric characters	-
DIO monitor and operation setting > Tag comment	Up to 8 alphanumeric characters	-
DIO monitor and operation setting > Operation property >ON > Label	Up to 8 alphanumeric characters	-
DIO monitor and operation setting > Operation property >ON > Color	Red, green, blue, blue violet, brown, orange, yellow-green, light blue, violet, gray, lime, cyan, dark blue, yellow, light gray, or purple	Red
DIO monitor and operation setting > Operation property >OFF > Label	Up to 8 alphanumeric characters	-
DIO monitor and operation setting > Operation property >OFF > Color	Red, green, blue, blue violet, brown, orange, yellow-green, light blue, violet, gray, lime, cyan, dark blue, yellow, light gray, or purple	Red

<#4 DI/DO label setting>

Parameter	Selectable Range or Selections	Initial Value
DI/DO label setting > Module	CTRL1-DI, CTRL2-DI, CTRL3-DI, EXT1-RI, CTRL1-DO, CTRL2-DO, CTRL3-DO, EXT1-RO	CTRL1-DI
DI/DO label setting > DI001 to DI006 > Label	Up to 16 alphanumeric characters	DI001 to DI006
DI/DO label setting > DI101 to DI106 > Label	Up to 16 alphanumeric characters	DI101 to DI106
DI/DO label setting > DI201 to DI206 > Label	Up to 16 alphanumeric characters	DI201 to DI206
DI/DO label setting > RI001 to RI006 > Label	Up to 16 alphanumeric characters	RI001 to RI006
DI/DO label setting > DO001 to DO006 > Label	Up to 16 alphanumeric characters	DO001 to DO006
DI/DO label setting > DO101 to DO106 > Label	Up to 16 alphanumeric characters	DO101 to DO106
DI/DO label setting > DO201 to DO206 > Label	Up to 16 alphanumeric characters	DO201 to DO206
DI/DO label setting > RO001 to RO006 > Label	Up to 16 alphanumeric characters	RO001 to RO006

#9 Detailed settings (#8 when the program control function is OFF)**<#1 PV/SP math, Retransmission>**

Parameter	Selectable Range or Selections	Initial Value
PV/SP math, Retransmissin > Loop number	1 to 6	1
PV/SP math, Retransmissin > PV/SP	PV, PV1, PV2, SP (Depending on the control mode)	Value depending on the control mode
PV/SP math, Retransmissin > Mode	On/Off	Off
PV/SP math, Retransmissin > Calculation expression	Up to 120 alphanumeric characters	Previously determined control input channel No.
PV/SP math, Retransmissin > PV range > Lower-limit	-30000 to 30000 (upper-lower ≤ 30000)	Measurement range of calculation expression initial vlue
PV/SP math, Retransmissin > PV range > Upper-limit	-30000 to 30000 (upper-lower ≤ 30000)	Measurement range of calculation expression initial vlue
PV/SP math, Retransmissin > Unit	Up to 6 alphanumeric characters	-
PV/SP math, Retransmissin > PV swithing > Lower	-30000 to 30000 (upper-lower ≤ 30000)	Lower limit of PV range
PV/SP math, Retransmissin > PV swithing > Upper	-30000 to 30000 (upper-lower ≤ 30000)	Upper limit of PV range
PV/SP math, Retransmissin > Math error	Over, Under	Over

<#2 Logic math>

Parameter	Selectable Range or Selections	Initial Value
Logic math > Setting number	1-6, 7-12, 13-18, 19-24, 25-30	1-6
Logic math > Relay	Off, DO001 to DO006, DO101 to DO106, DO201 to DO206, Ro001 to RO012, SW001 to SW036	Off
Logic math > Calculation expression	Up to 120 alphanumeric characters	-

<#3 Constant>

Parameter	Selectable Range or Selections	Initial Value
Constant > W01 to W36	-9.9999E+29 to -1.0000E-30, 0, 1.0000E-30 to 9.9999E+29	1

List of Parameters

Set mode

#1 Range, Alarm

Parameter	Selectable Range or Selections	Initial Value
First-CH	01 to 20	01
Last-CH	01 to 20	01
Range > Mode	Volt, TC, RTD, Scale, Delta, DI, Sqrt, or Skip	Volt
Range > Range	20 mV, 60 mV, 200 mV, 2 V, 6 V, 20 V, 50 V, R, S, B, K, E, J, T, N, W, L, U, PLATI, PR, Wre, PT, JPT, Level, or Cont	2 V
Range > Span Lower	–	–2.000
Range > Span Upper	–	2.000
Alarm > 1 to 4	On/Off	Off
Alarm > Type	H: High limit, L: Low limit, R: Rate-of-change, T: Delay high, t: Delay low	H
Alarm > Value	–	0.000
Alarm > Relay On/off	On/Off	Off
Alarm > Relay Number	I01 to I06, DO001 to DO006, DO101 to DO106, DO201 to DO206, RO001 to RO012, or SW001 to SW036	I01
Alarm > Detect	On/Off	On

#2 Tag, Moving average, Alarm delay

Parameter	Selectable Range or Selections	Initial Value
First-CH	01 to 20, 101 to 118, or 201 to 248	01
Last-CH	01 to 20, 101 to 118, 201 to 248	01
Tag	Up to 16 alphanumeric characters	01
Moving average > Count	Off, 2, 3, 4, 5, 6, 7, 8, 9, 10, 11, 12, 13, 14, 15, or 16	Off
Alarm delay > Time	1 s to 3600 s	10 s

#3 Trend/Save interval, Message, File, User key, DST

Parameter	Selectable Range or Selections	Initial Value
Trend/Save interval > Time/div	1 min, 2 min, 5 min, 10 min, 20 min, 30 min, 1 h, 2 h, 4 h, or 10 h	1 min
Trend/Save interval > Auto save interval	10 minutes to 31 days	1h
Message > Characters No. 1 to No. 8	Up to 16 alphanumeric characters	–
File > Header	Up to 32 alphanumeric characters	–
File > Directory name	Up to 8 alphanumeric characters	DATA0
File > Save data	Unsave or All	All
USER key > Action	None, Trigger, AlarmACK, MathStart/Stop, MathReset, ManualSample, Message1 - Message8, or Snapshot	AlarmACK
Daylight saving time (YY/MM/DD HH) > Summer	Off/On	Off
Daylight saving time (YY/MM/DD HH) > Winter	Off/On	Off

#4 Display

<#1 Group set, Trip line>

Parameter	Selectable Range or Selections	Initial Value
Group number	1 to 10	1
Group set > Group name	Up to 16 alphanumeric characters	GROUP 1
Group set > CH set	–	01-10
Group set > Trip line > No. 1 to No. 4	On/Off	Off
Group set > Trip line > Position	0% to 100%	100%
Group set > Trip line > Color	Red, green, blue, blue violet, brown, orange, yellow-green, light blue, violet, gray, lime, cyan, dark blue, yellow, light gray, or purple	No.1: Red, No.2: Green, No.3: Blue, No.4: Yellow

<#2 Color>

Parameter	Selectable Range or Selections	Initial Value
Color > CH1, CH11	Red, green, blue, blue violet, brown, orange, yellow-green, light blue, violet, gray, lime, cyan, dark blue, yellow, light gray, or purple	Red
Color > CH2, CH12	Same as above	Green
Color > CH3, CH13	Same as above	Blue
Color > CH4, CH14	Same as above	Blue-violet
Color > CH5, CH15	Same as above	Brown
Color > CH6, CH16	Same as above	Orange
Color > CH7, CH17	Same as above	Yellow-green
Color > CH8, CH18	Same as above	Light blue
Color > CH9, CH19	Same as above	Violet
Color > CH10, CH20	Same as above	Gray

<#3 Zone, Graph, Partial>

Parameter	Selectable Range or Selections	Initial Value
First-CH	01 to 20	01
Last-CH	01 to 20	01
Zone > Lower	0% to 95%	0%
Zone > Upper	5% to 100%	100%
Graph > Division	4, 5, 6, 7, 8, 9, 10, 11, 12, or C10	10
Graph > Bar graph	Normal or Center	Normal
Graph > Scale position	Off or 1 to 10	1
Partial	On/Off	Off
Expand	1% to 99%	50%
Boundary	Minimum span value + 1 digit to maximum span value – 1 digit or minimum scale value + 1 digit to maximum scale value – 1 digit (when the channel is set to scaling or square root computation)	0.000

<#4 View, Direction, LCD>

Parameter	Selectable Range or Selections	Initial Value
View > Direction > Trend	Horizontal, Vertical, or Horizon2	Horizontal
View > Direction > Bar graph	Horizontal or Vertical	Vertical
View > Background > Measure	White or Black	White
View > Background > Control	White or Black	Black
View > Trend line	1, 2, or 3 dots	2 dots
View > Trip line	1, 2, or 3 dots	2 dots
View > Grid	Auto, 4 div, 5 div, 6 div, 7 div, 8 div, 9 div, 10 div, 11 div, or 12 div	10 div
View > Scroll	5 s, 10 s, 20 s, 30 s, 1 min	5s
View > Scale digit	Normal or Fine	Normal
LCD > Brightness	1 to 4	3
LCD > Backlight saver > On/Off	On/Off	Off
LCD > Backlight saver > Saver time	1 min, 2 min, 5 min, 10 min, 30 min, or 1 h	1 h
LCD > Restore	Key or Key+Alm	Key+Alm

<#5 Control (Color)>

Parameter	Selectable Range or Selections	Initial Value
Select	Internal, Ext1, Ext2, or Ext3	Internal
CH101, CH110, CH201...CH237...CH246	Red, green, blue, blue violet, brown, orange, yellow-green, light blue, violet, gray, lime, cyan, dark blue, yellow, light gray, or purple	Red
CH102, CH111, CH202...CH238...CH247	Same as above	Green
CH103, CH112, CH203...CH239...CH248	Same as above	Blue
CH104, CH113, CH204...CH240	Same as above	Blue-violet
CH105, CH114, CH205...CH241	Same as above	Brown
CH106, CH115, CH206...CH242	Same as above	Orange
CH107, CH116, CH207...CH243	Same as above	Yellow-green
CH108, CH117, CH208...CH244	Same as above	Light blue
CH109, CH118, CH209...CH245	Same as above	Violet

List of Parameters

<#6 Control (Zone, Graph (, Partial))>

Parameter	Selectable Range or Selections	Initial Value
First-CH	101 to 118 or 201 to 248	101
Last-CH	101 to 118 or 201 to 248	101
Zone Lower	0% to 95%	0%
Zone Upper	5% to 100%	100%
Division	4, 5, 6, 7, 8, 9, 10, 11, 12, or C10	10
Bar graph	Normal or Center	Normal
Scale position	Off or 1 to 10	1
Partial	On/Off	Off
Expand	1% to 99%	50%
Boundary	Minimum span value + 1 digit to maximum span value – 1 digit or minimum scale value + 1 digit to maximum scale value – 1 digit (when the channel is set to scaling or square root computation)	0.1

<#7 Math (Color)>

Parameter	Selectable Range or Selections	Initial Value
CH31, CH41, CH51	Red, green, blue, blue violet, brown, orange, yellow-green, light blue, violet, gray, lime, cyan, dark blue, yellow, light gray, or purple	Red
CH32, CH42, CH52	Same as above	Green
CH33, CH43, CH53	Same as above	Blue
CH34, CH44, CH54	Same as above	Blue-violet
CH35, CH45, CH55	Same as above	Brown
CH36, CH46, CH56	Same as above	Orange
CH37, CH47, CH57	Same as above	Yellow-green
CH38, CH48, CH58	Same as above	Light blue
CH39, CH49, CH59	Same as above	Violet
CH40, CH50, CH60	Same as above	Gray

<#8 Math (Zone, Graph (, Partial))>

Parameter	Selectable Range or Selections	Initial Value
First-CH	31 to 60	31
Last-CH	31 to 60	31
Zone > Lower	0% to 95%	0%
Zone > Upper	5% to 100%	100%
Graph > Division	4, 5, 6, 7, 8, 9, 10, 11, 12, or C10	10
Graph > Bar graph	Normal or Center	Normal
Graph > Scale position	Off or 1 to 10	1
Partial	On/Off	Off
Expand	1% to 99%	50%
Boundary	Minimum span value + 1 digit to maximum span value – 1 digit or minimum scale value + 1 digit to maximum scale value – 1 digit (when the channel is set to scaling or square root computation)	0.00

#5 Save/Load, Clear data

Parameter	Selectable Range or Selections	Initial Value
#1 Save settings	–	–
#2 Load settings	–	–
#3 Save data	–	–
#4 Load display data	–	–
#5 Load event data	–	–
#6 File list	–	–
#7 Delete	–	–
#8 Format	–	–
#9 Clear data	–	–

#6 Time

Parameter	Selectable Range or Selections	Initial Value
Time set > YY/MM/DD HH/MM/SS	–	–

#7 Math set1 (expression, alarm, constant)

Parameter	Selectable Range or Selections	Initial Value
First-CH	31 to 60	31
Last-CH	31 to 60	31
Math range > Math On/Off	On/Off	Off
Math range > Calculation expression	40 characters or less.	01
Math range > Span Lower	–9999999 to 99999999 (decimal point: within 4 digits to the right of the decimal point)	–200.00
Math range > Span Upper	–9999999 to 99999999 (decimal point: within 4 digits to the right of the decimal point)	200.00
Math range > Unit	Up to 6 alphanumeric characters	–
Alarm > 1 to 4	On/Off	Off
Alarm > Type	H, L, T, or t	H
Alarm > Value	Value within the measurement span	0.00
Alarm > Relay On/Off	On/Off	Off
Alarm > Relay Number	I01 to I06, DO001 to DO006, DO101 to DO106, DO201 to DO206, RO001 to RO012, or SW001 to SW036	I01
Alarm > Detect	On/Off	On
Constant > K01 to K30	–9.9999E+29 to –1.0000E–30, 0, 1.0000E–30 to 9.9999E+29	1

#8 Math set2 (tag, TLOG, rolling average, alarm delay)

Parameter	Selectable Range or Selections	Initial Value
First-CH	31 to 60	31
Last-CH	31 to 60	31
Tag > Tag	Up to 16 alphanumeric characters	31
TLOG > Timer No.	1, 2, or 3	1
TLOG > Sum scale	Off, /s, /min, or /h	Off
Rolling average > On/Off	On/Off	Off
Rolling average > Interval	1 s, 2 s, 3 s, 4 s, 5 s, 6 s, 10 s, 12s, 15s, 20s, 30s, 1 min, 2 min, 3 min, 4 min, 5 min, 6 min, 10 min, 12 min, 15 min, 20 min, 30 min, or 1 h	10 s
Rolling average > Number of samples	1 to 64	1
Alarm delay	1 s to 3600 s	10 s

#9 Batch set

Parameter	Selectable Range or Selections	Initial Value
Application name	Up to 16 alphanumeric characters	–
Supervisor name	Up to 16 alphanumeric characters	–
Manager name	Up to 16 alphanumeric characters	–
Batch number	Up to 16 alphanumeric characters	–
Lot number	Up to 4 alphanumeric characters	–
Auto increment	On/Off	On
Disp information	Batch, Time	Batch